



Champion Fiberglass™
STRUT™



Champion Fiberglass is the most advanced manufacturing facility of fiberglass conduit, fiberglass bridge drain and fiberglass strut systems in the world. Its well-trained and highly efficient workforce utilizes state-of-the-art proprietary high-speed winding equipment and high-temperature curing ovens to develop the world's most advanced, highest-quality fiberglass conduit and bridge drain systems. Our 111,300 square-foot facility includes two state-of-the-art fiberglass filament winding production lines that have now been joined by a third line. This third production line features updated technology that will speed output and double our filament winding capacity rate of manufacture - thereby increasing our ability to deliver quicker, more customized solutions for our customers.

Champion Fiberglass is both an ISO 9001:2015 and ISO 14001:2015-certified company. The Champion Fiberglass facility is currently a 100% digital, high-volume manufacturing facility. With the addition of our new third leading-edge production line, we're taking our customer commitment to a new level by delivering much higher-quality, cost-efficient products at a much faster rate.

Champion Strut™ is a fiberglass non-metallic channel framing system that includes a complete line of non-metallic accessories, fasteners, hangers, pipe clamps and channels. Champion Strut is a versatile, high-strength fiberglass framing system that has been successfully used in many highly corrosive applications including steel mills, wastewater treatment, rendering facilities, utilities, refineries, chemical plants, marinas, pulp and paper, desalination facilities, water reclamation facilities, theme parks, aquariums, pools and underground vaults. The Champion Strut is pultruded from corrosion-resistant polyester and vinyl ester resin and the accessories are injection molded from glass-reinforced polyurethane which enables the Champion Strut system to be used in highly corrosive applications where steel strut systems would traditionally fail. Champion Strut incorporates the highest-quality components to provide superior chemical, UV and fire resistance. Champion Strut has a complete network of sales representatives and distributors that can provide the necessary assistance.

Features and Advantages

Champion Strut offers the following features and advantages:

- Multiple channel profiles to accommodate any application
- Available in both polyester (dark grey) and vinyl ester (beige) resin systems
- Light grey colored polyester channel is available upon special request with a special part number
- Supplied in standard 10-ft lengths with 20-ft lengths available upon request
- CS-SST Series Channel (only) will accommodate stainless steel pipe straps
- Complete line of corrosion-resistant fiberglass components
- UV resistant - channels incorporate UV inhibitors and surfacing veil which improves weatherability and inhibits UV degradation
- Easy to field cut and drill
- Lightweight
- Fire retardant
- Special colors available upon request



Contents

Pages 2-5

Technical Information

Pages 6-8

Installation

Pages 9-10

Chemical Resistance

Pages 11-19

Channel

Pages 20-25

Channel Fittings

Pages 26-30

Pipe Clamps

Pages 31-35

Fasteners

Page 36

Pipe and Conduit Hangers

Pages 37-39

Pipe and Conduit Hanger Types

Pages 40-41

Specifications for
Fiberglass Hangers

Pages 42-43

Pipe and Conduit Hangers

Pages 43-45

Pipe Hanging Accessories

Page 46

Wall Support Racks

Pages 46-49

Instruments and Pipe Stands

Pages 50-51

Promotional Samples

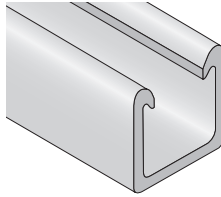

Channel Pages 11-19

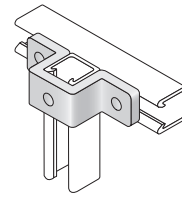

Channel Fittings Pages 20-25

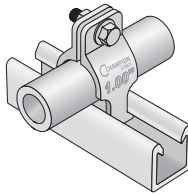

Pipe Clamps Pages 26-30

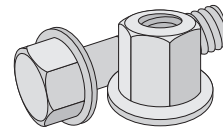

Fasteners Pages 31-35

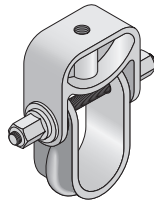

Pipe and Conduit Hangers Pages 42-43

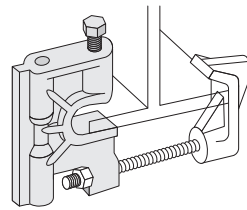

Pipe Hanging Accessories Pages 43-45

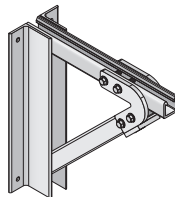

Wall Support Racks Page 46

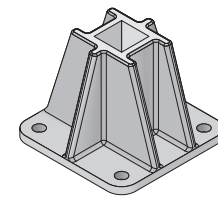

Instruments and Pipe Stands Pages 46-49

Technical Information

Channels

Channels are provided in two different resin systems, polyester and vinyl ester resin. These channels are manufactured from a process called pultrusion. Both polyester and vinyl ester channels utilize the same glass rovings and matting with the only difference being the resins. Even though they utilize the same glass rovings and mattings, they exhibit different physical properties. Both resins are flame retardant conforming to ASTM E-84, Class 1 flame spread rating and are self-extinguishing per the requirements of UL94V-0. Both polyester and vinyl ester channels also incorporate UV-resistant surfacing veils. However, since each resin system has its own advantages, it's up to the user to determine which resin system offers the best solution for their application(s).

Materials

Polyester Resin

Polyester resin channels are provided in a dark grey color for CS-S Series channels and a light grey color for CS-SST Series Channels. Polyester channel special colors are available upon request. Polyester resin channels are great general-purpose fiberglass channels that provide very good corrosion resistance in many chemical environments. Polyester resin channels are generally less expensive than vinyl ester channels as well.

Vinyl Ester Resin

Vinyl ester resin channels are provided in beige colors for both the CS-S Series channels and for the CS-SST Series channels. Vinyl ester channel special colors are available upon request. Vinyl ester resin channels are premium-grade fiberglass channels that provide superior corrosion resistance in many chemical environments. Vinyl ester channels are more resistant to impact and less sensitive to temperature and humidity, thus making them more durable and expensive than polyester resin channels.

Polyurethane Resin

Glass-reinforced polyurethane resin is used to manufacture Champion Strut™ pipe clamps, U-bolts, hardware, some channel connector fittings, molded clevis hangers and post bases. These parts are all colored dark grey.

Temperature Ranges

The Champion Strut system utilizes three material types. The following chart illustrates their acceptable operating temperature ranges.

MATERIAL TYPE	LOW TEMPERATURE	HIGH TEMPERATURE
Polyester	-35°F	200°F
Vinyl Ester	-35°F	200°F
Polyurethane	-40°F	140°F

Manufacturing Process

Pultrusion

Pultrusion is a continuous molding process whereby glass reinforcing fibers, glass mattings and UV-resistant surfacing veils are saturated with a liquid polymer (polyester or vinyl ester) resin and then carefully formed and pulled through a heated die to form a part. Pultrusion results in straight, consistent parts of virtually any length. Being that the pultruded component is internally reinforced with permanently bonded continuous glass fibers, it has great strength. In addition to being strong, pultruded components demonstrate excellent corrosion and fire resistance. These features make fiberglass channel an excellent choice for many corrosive industrial applications.

TYPICAL PROPERTIES	TEST METHOD	DIRECTION	UNIT	TYPICAL VALUE POLYESTER	TYPICAL VALUE VINYL ESTER
MECHANICAL					
Ultimate Tensile Strength	ASTM D-638	Longitudinal	PSI	30,000	35,000
	ASTM D-638	Transverse	PSI	7,000	10,000
Tensile Modulus	ASTM D-638	Longitudinal	PSI	2.5 x 10 ⁶	3.0 x 10 ⁶
	ASTM D-638	Transverse	PSI	0.8 x 10 ⁶	1.0 x 10 ⁶
Ultimate Compressive Strength	ASTM D-695	Longitudinal	PSI	30,000	35,000
	ASTM D-695	Transverse	PSI	15,000	20,000
Compressive Modulus	ASTM D-695	Longitudinal	PSI	2.5 x 10 ⁶	2.5 x 10 ⁶
	ASTM D-695	Transverse	PSI	1.0 x 10 ⁶	1.2 x 10 ⁶
Ultimate Flexural Strength	ASTM D-790	Longitudinal	PSI	30,000	35,000
	ASTM D-790	Transverse	PSI	10,000	14,000
Flexural Modulus	ASTM D-790	Longitudinal	PSI	1.6 x 10 ⁶	2.0 x 10 ⁶
	ASTM D-790	Transverse	PSI	0.8 x 10 ⁶	1.0 x 10 ⁶
Shear Strength Short Beam	ASTM D-2344	Longitudinal or	PSI	5,500	7,000
		Transverse	PSI	5,500	6,000
Impact Strength-Izod	ASTM D-256	Longitudinal	ft-lb/in	35	30
		Transverse	ft-lb/in	4	5
Hardness-Barcol	ASTM D-2583	Perpendicular	-	50	50
ELECTRICAL					
Electrical Strength Short Time-in oil	ASTM D-149	Perpendicular	PSI	200	200
		Parallel	PSI	35	35
Dielectric Constant	ASTM D-150	Perpendicular	PSI	5.0	5.0
Dissipation Factor	ASTM D-150	Perpendicular	PSI	0.03	0.03
Arc Resistance	ASTM D-495	Longitudinal or	PSI	80	120
		Transverse	PSI	80	120

The fiberglass channels provided by Champion Strut™ are standardly supplied in 10-ft lengths with 20-ft lengths available upon request.

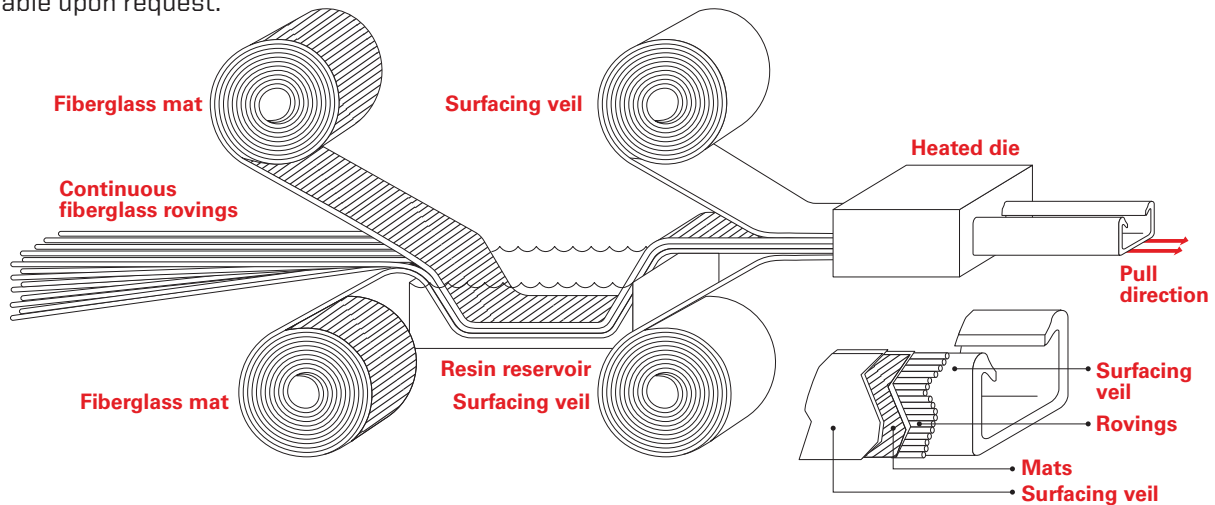

TYPICAL PROPERTIES	TEST METHOD	DIRECTION	UNIT	TYPICAL VALUE POLYESTER	TYPICAL VALUE VINYL ESTER
OTHER					
Thermal Coefficient of Expansion	ASTM D-696	Longitudinal	in/in/°F	5 x 10 ⁻⁵	5 x 10 ⁻⁵
Thermal Conductivity		Longitudinal	BTU/Hr sq	4.0	4.0
			PSI		
Water Absorption 24 hours	ASTM O-570	Longitudinal	%	1	1
Density	ASTM D-792	Longitudinal	lbs/cu in	0.062	0.062
Color (Standard)				Dark Grey	Beige
Flammability	UL94		Classification:	V-0	V-0
Flammability	ASTM E-84		Rating:	25	25

The above list of properties was derived from laboratory data using coupon test specimens cut from pultruded sections. Such information should only be used as a general guide in design. The factory should be contacted for specific information on any given component.

Weathering

All fiberglass pultruded parts will experience some degradation after prolonged exposure to outdoor weathering. Pultruded fiberglass components have excellent corrosion and temperature resistance but can be attacked by UV. Degradation first becomes apparent when the pultruded component surface loses its shiny appearance and gloss. Over longer periods and in severe cases, the fiberglass closest to the surface will become exposed; however, even in this advanced state, the physical properties of the pultruded part are not compromised by this surface degradation. The Champion Strut fiberglass channel framing system includes dark pigments, UV stabilizers and a surfacing veil to inhibit the effects of weathering and UV degradation. The surfacing veil provides a resin-rich surface which inhibits weathering and acts as a barrier from UV degradation between the surface and the top layer of the fiberglass-reinforced pultruded component. The addition of pigments used within the resin also slow the effects of weathering. The best overall method to protect pultruded components from the effects of outdoor weathering is to apply a protective coating. Champion recommends coating the pultruded components with an outdoor urethane or acrylate paint. This will protect the pultruded components from the future effects of weathering and prolong the fiberglass channel framing system life.

If your application will experience extreme exposure to ultraviolet, please contact Champion Fiberglass to discuss the extreme ultraviolet-resistant fiberglass channel framing system options that are available.

Handling and Storage

Transportation

Fiberglass channels are shipped in self-supporting crates designed to be unloaded by forklift. Crates should not be dropped from the truck trailer flatbeds. Fiberglass channels may also be shipped via enclosed vans in bundles. Smaller lengths of channel (under 5 ft) can be shipped via common courier delivery service.

Storage

- **Fiberglass channel** crates should be stored on a flat, level surface. The wooden frames should line up so the load will be transferred to the wood frames rather than the channel. The height of stacked channel should be limited to 12 ft.
- **Channel accessories**, when stored outdoors, should be under cover to protect items in cartons from the outdoor elements until ready for installation.

Champion Strut™ Specifications

1.0 Scope

- 1.1 This specification covers the requirements for the Champion Strut fiberglass channel framing system

2.0 Materials

- 2.1 Channels shall be pultruded from fire-resistant polyester and vinyl ester resins. Polyester and vinyl ester resins utilized will have a fire-retardant rating of 25 or less when tested in accordance with ASTM E-84 and exhibit low smoke generation. Polyester resin channels provided will be dark grey in color (CS-S Series channels) or light grey in color (CS-SST Series channels). Vinyl ester channels provided will be beige in color (CS-S Series channels and CS-SST Series channels). Special colors are available upon request.
- 2.2 Some channel accessories will be constructed from pultruded polyester and vinyl ester materials. Other channel accessories will be injection molded from long glass fiber-reinforced polyurethane resin.

3.0 Composition

- 3.1 Glass-reinforced channels will be constructed with 70% glass and 30% resin. Channels will utilize UV-stabilized resins (polyester or vinyl ester) and incorporate UV-resistant surfacing veil into the laminate. Surfacing veils will be applied to all exterior surfaces to improve weatherability and inhibit ultraviolet degradation.
- 3.2 Glass-reinforced channel accessories will be injection molded from 40% long glass fiber polyurethane resin. Channel accessories will incorporate dark grey pigments to improve weatherability and inhibit ultraviolet degradation.

4.0 Structural Design

4.1 Champion Strut™ CS-S Series channel profile is designed to allow complete engagement and maximum pull-out strength of channel accessories. Flange design provides maximum strength compared to traditional fiberglass channel profile flange designs and permits greater torquing of accessories without failure.

The Champion Strut CS-SST Series channel profile is designed strictly to be used with traditional steel pipe clamps. Champion Strut CS-SST Series channel profile is not designed to be used with any polyurethane channel accessories pictured in this catalog. The CS-SST Series channel flange design will not interlock correctly with these accessories causing potential failures.

4.2 Champion Strut channel profiles will be offered in the following sizes:

CS-S SERIES	CS-SST SERIES
1-1/2" x 1-1/8" x 1/8"	1-5/8" x 1-1/8" x 3/16"
1-1/2" x 2-1/4" x 1/8"	1-5/8" x 2-1/4" x 3/16"
1-5/8" x 1-5/8" x 1/4"	1-5/8" x 1-5/8" x 3/16"
1-5/8" x 3-1/4" x 1/4"	1-5/8" x 3-1/4" x 3/16"

CS-S Series

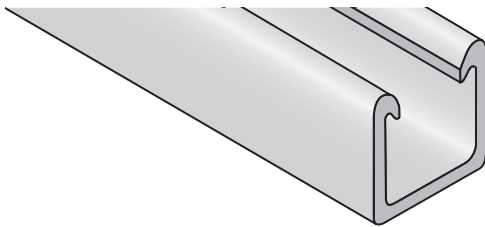

CS-SST Series

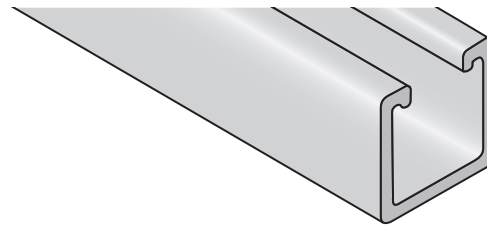

4.3 Champion Strut CS-S Series channel profile will have a minimum flange pull-out strength of 1,000 lbs over 3/4"-long section of inside flange.

4.4 Champion Strut channel lengths shall be standardly supplied in 10-ft lengths with 20-ft lengths available upon special request.

5.0 Standards

- 5.1 Champion Strut channel shall conform to UL94V0 self-extinguishing flammability standard.
- 5.2 Champion Strut shall have a flame spread rating of 25 or less when tested per ASTM E-84.
- 5.3 Champion Strut channel complies with the requirements of ASTM D-3917 and ASTM D-4385 which govern the dimensional tolerances and visual defects of pultruded shapes.

6.0 Quality Assurance

6.1 Manufacturer shall have a current Certificate, issued by an independent and accredited company, of compliance with an ISO 9001: 2015 Quality Management System.

7.0 General

- 7.1 Champion Strut shall be supplied as a system including all necessary non-metallic components (fasteners, hangers, pipe clamps, channel splice plates, brackets, beam clamps, etc.)
- 7.2 All Champion Strut components supplied shall be non-metallic except where 316 stainless steel hardware is used as part of the specific component.
- 7.3 Non-metallic fasteners shall be manufactured from long glass fiber-reinforced polyurethane. These fasteners combine high levels of stiffness, strength and toughness all together in a single material. No other method of reinforcing melt processable thermoplastic is able to match their performance properties.
- 7.4 Champion Strut is manufactured in the U.S.A. (Spring, TX) by Champion Fiberglass.

8.0 Environmental

Manufacturer shall have a current Certificate, issued by an independent and accredited company, of compliance with an ISO 14001: Environmental Management Systems and Performance.

Installation

These instructions are intended only to provide assistance and as a guide to obtain the most appropriate and satisfactory installation of Champion Strut™ fiberglass channel framing systems.

These instructions are not intended to replace the responsibilities of engineers, customer representatives, owners or other persons responsible in establishing engineering design practices and procedures that are best suited for individual job site conditions.

The installation of fiberglass channel and accessories doesn't differ greatly from the installation of metallic channel and accessories. General installation practices will still apply. The procedures for cutting, drilling and sealing can be found below.

Labor Savings

Just as with Champion Fiberglass conduit, Champion Strut can be installed much faster than traditional steel channels. The lightweight fiberglass components weigh less than half of their steel channel counterparts and can be cut, drilled and fabricated in half the time. The result is a substantial labor savings.

Field Cutting, Drilling and Sealing

To make fiberglass channel field cuts, the tools required are a fine-tooth hand-held hack saw, porta-band saw or a chop saw with a diamond cutting blade. In order to drill fiberglass channel, any standard battery-powered drill will work. It's recommended to use carbide-tipped drill bits as they last longer. Marking the fiberglass channel for cutting or drilling will require a contrasting colored marker. Remove any cutting/drilling burrs or ridges with 60-grit emery cloth. All field cut sections of strut should be sealed with Champion Seal field cutting sealant (PN# CS-SEAL-C).

Proper field cutting and drilling PPE to include:

- Long sleeve clothing
- Gloves
- Safety glasses
- Particulate respirator (#N95 or equivalent)



CHAMPION STRUT™ WALL BRACKETS

Champion Strut wall brackets are typically used to support piping, electrical conduits or cable trays that will be wall mounted. Each wall bracket has a maximum load rating of 750 lbs with a 3:1 safety factor on a uniformly distributed load. Bracket spacing may be determined by dividing 750 lbs by the piping, electrical conduit or cable tray load by the total load in lbs/ft of piping, conduit or cable tray including its intended material load (fluid or cable).

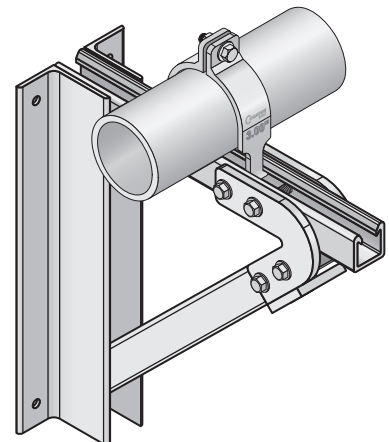

TRAPEZE HANGING SYSTEMS

Champion Strut trapeze hanging systems may be used to support piping, electrical conduits or electrical cable trays in areas where the building structure doesn't allow direct placement or supporting (I-beams, wall mounting, pipe racks, etc.). Trapeze hangers are field assembled using components that are contained within this catalog. The trapeze hanger should be constructed as shown and care should be taken to ensure that the load is equally distributed on the hanger and that threaded rods are completely inserted fully into the beam clamps to achieve maximum thread engagement and threaded rod pull-out strength.

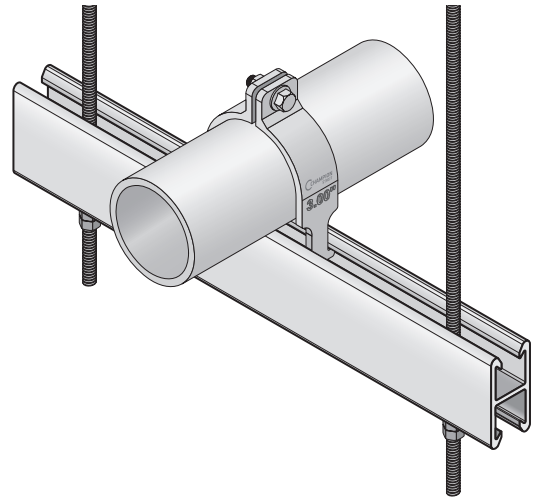

CHAMPION STRUT™ TRAPEZE TYPES

The Champion Strut trapeze systems can be designed in three different styles; utilizing the single back-to-back Champion Strut CS-Series profile CS-S20D, with the CS-S Series 1-5/8" x 1-5/8" profile CS-S10D with the strut opening facing down or the CS-S Series 1-5/8" x 1-5/8" profile CS-S10D with the strut opening facing up. Each type of trapeze hanging system has different loading capacities.

BACK-TO-BACK STRUT TRAPEZE

When utilizing this design and supporting a 100 lb/ft load, the spacing between each trapeze should not exceed 10 ft. Under these conditions, each trapeze will be supporting 1,000 lbs and yielding a support system safety factor of 3. When using the Champion Strut heavy-duty fiberglass beam clamps (PN# CS-BCH-500), care should be taken to ensure that the 1/2" threaded rod is fully engaged within the beam clamp. The fiberglass hex nuts should not be over-torqued (8 ft/lbs max) and the load should be equally distributed over the trapeze hanger.

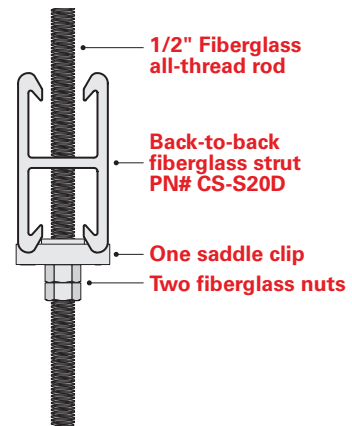
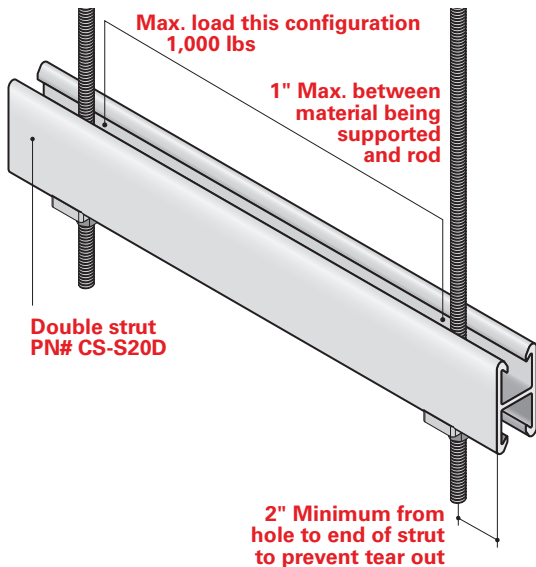

SINGLE STRUT (CS-S20) WITH OPEN END FACING DOWN TRAPEZE

When utilizing this design and supporting a 100 lb/ft load, the spacing between each trapeze should not exceed 5 ft. Under these conditions, each trapeze will be supporting 500 lbs and yielding a support system safety factor of 3. When using the Champion Strut™ heavy-duty fiberglass beam clamps (PN# CS-BCH-500), care should be taken to ensure that the 1/2" threaded rod is fully engaged within the beam clamp. The fiberglass hex nuts should not be over-torqued (8 ft/lbs max) and the load should be equally distributed over the trapeze hanger.

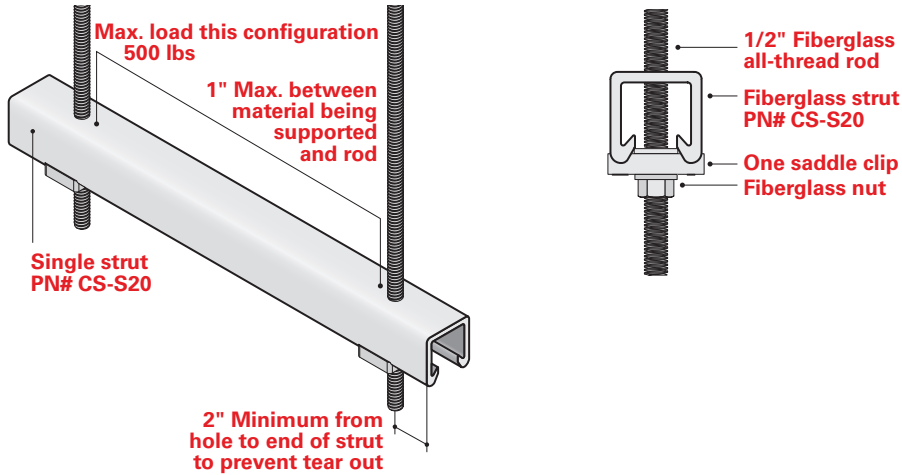

SINGLE STRUT (CS-S20) WITH OPEN END FACING UP TRAPEZE

When utilizing this design and supporting a 100 lb/ft load, the spacing between each trapeze should not exceed 4 ft. Under these conditions, each trapeze will be supporting 400 lbs and yielding a support system safety factor of 3. When using the Champion Strut heavy-duty fiberglass beam clamps (PN# CS-BCH-500), care should be taken to ensure that the 1/2" threaded rod is fully engaged within the beam clamp. The fiberglass hex nuts should not be over-torqued (8 ft/lbs max) and the load should be equally distributed over the trapeze hanger.

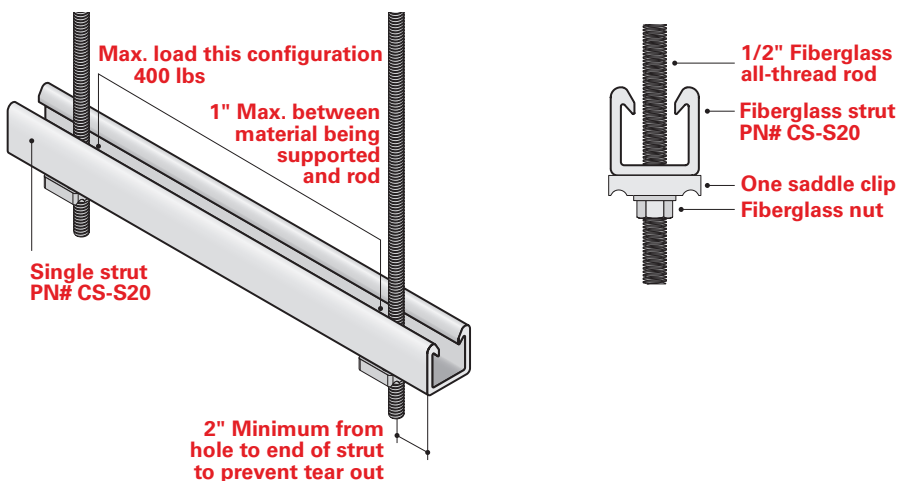

Chemical Resistance

Chemical Compatibility Table

CHEMICAL	SERIES P (POLY/GLASS) 70°–160°F		SERIES V (VINYL/GLASS) 70°–160°F		SERIES PU (POLYURETHANE) 70°–160°F	
	70°F	160°F	70°F	160°F	70°F	160°F
Acetic Acid, Up to 10%	R	R	R	R	R	–
Acetic Acid, Up to 50%	R	R	R	R	R	–
Acetone, Up to 10%	NR	NR	NR	NR	R	–
Aluminum Hydroxide	R	R	R	R	R	–
Ammonium Hydroxide (Aqueous Ammonia), Up to 5%	NR	NR	R	R	R	–
Ammonium Hydroxide, Up to 10%	NR	NR	R	150°	R	–
Ammonium Hydroxide, Up to 20%	NR	NR	R	150°	R	–
Ammonium Nitrate	R	R	R	R	R	–
Ammonium Phosphate	R	R	R	R	R	–
Ammonium Sulfide, Saturated	NR	NR	R	120°	R	–
Aqua Regia, fumes	NR	NR	R	150°	NR	–
Benzene NR	NR	NR	NR	NR	R	R
Benzoic Acid	R	R	R	R	R	–
Bromine, Wet Gas	NR	NR	R	150°	–	–
Butylene Glycol, Up to 100%	R	R	R	NR	R	–
Butyric Acid, Up to 50%	R	R	R	R	R	–
Calcium Hydroxide	R	NR	R	R	R	–
Calcium Hypochlorite	R	NR	R	R	R	–
Chlorine, Dry Gas	NR	NR	R	R	–	–
Chlorine, Wet Gas	NR	NR	R	R	–	–
Chlorine, Liquid	NR	NR	NR	NR	–	–
Chlorine, Water	R	R	R	R	R	–
Chromic Acid, Up to 5%	NR	NR	R	R	–	–
Copper Chloride	R	R	R	R	R	–
Copper Cyanide	R	NR	R	R	R	–
Copper Fluoride	R	NR	R	R	R	–
Copper Nitrate	R	R	R	R	R	–
Copper Sulfate	R	R	R	R	R	–
Dechlorinated Brine Storage	–	–	R	R	R	–
Esters, Fatty Acid	R	R	R	R	R	–
Ferric Chloride	R	R	R	R	R	–
Ferrous Chloride	R	R	R	R	R	–
Fluoboric Acid	R	120°	R	R	–	–
Fluosilicic Acid, Up to 10%	NR	NR	R	R	–	–
Fluosilicic Acid, Up to 32%	NR	NR	R	100°	–	–
Formic Acid, Up to 10%	NR	NR	R	R	R	–
Formic Acid, Up to 50%	NR	NR	R	100°	R	–
Gasoline, Aviation	R	NR	R	R	R	–
Green Liquor, Pulp Mill	–	–	R	R	–	–
Hydrochloric Acid, Up to 15%	R	NR	R	R	R	–

R = Recommended NR = Not recommended – = No information available



CHEMICAL	SERIES P (POLY/GLASS) 70°–160°F		SERIES V (VINYL/GLASS) 70°–160°F		SERIES PU (POLYURETHANE) 70°–160°F	
	70°F	160°F	70°F	160°F	70°F	160°F
Hydrochloric Acid, Up to 37%	R	NR	R	R	R	–
Hydrofluoric Acid, Up to 10%	NR	NR	R	150°	–	–
Hydrofluoric Acid, Up to 20%	NR	NR	R	100°	–	–
Hydrogen Chloride, Wet Gas	R	NR	R	R	NR	–
Hydrogen Sulfide, Wet Gas	R	NR	R	R	R	–
Lactic Acid	R	NR	R	R	R	–
Lead Nitrate	–	–	R	R	R	–
Magnesium Hydroxide	NR	NR	R	R	R	–
Nickel Sulfate, Low pH	NR	NR	R	R	R	–
Nickel Sulfate, High pH	NR	NR	R	R	R	–
Nitric Acid, Up to 5%	NR	NR	R	150°	R	–
Nitric Acid, Up to 35%	NR	NR	R	150°	R	–
Nitric Acid, Vapor	NR	NR	R	R	–	–
Perchloric Acid, Up to 10%	NR	NR	R	150°	–	–
Pickling Liquids, 3–5% H2SO4	R	R	R	R	R	–
Phosphoric Acid	NR	NR	R	R	R	–
Phosphoric Acid, Super or Poly (115%, P20%)	NR	NR	R	R	–	–
Phosphoric Acid, Vapor or Condensate	NR	NR	R	R	–	–
Potassium Chloride	R	R	R	R	R	–
Potassium Nitrate	R	R	R	R	R	–
Potassium Persulfate	NR	NR	R	R	R	–
Silver Cyanide, Up to 5%	NR	NR	R	R	R	–
Sodium Hydroxide, Up to 25%	NR	NR	R	150°	R	–
Sodium Hydroxide, Up to 50%	NR	NR	R	180°	–	–
Sodium Hypochlorite, Up to 15%	NR	NR	R	150°	R	–
Sodium Nitrate	R	R	R	R	R	–
Sodium Sulfate	R	NR	R	R	R	–
Sodium Sulfide	NR	NR	R	R	R	–
Sulfuric Acid, Up to 25%	R	R	R	R	R	–
Sulfuric Acid, Up to 50%	NR	NR	R	R	R	–
Sulfuric Acid, Up to 70%	NR	NR	R	R	R	–
Sulfuric Acid, Up to 75%	NR	NR	R	120°	–	–
Sulfuric Acid, Up to 80%	NR	NR	NR	NR	–	–
Sulfuric Acid, Vapor	R	NR	R	R	–	–
Trichlorethylene, Fumes	NR	NR	R	120°	R	–
Trisodium Phosphate	R	NR	R	R	R	–
Urea	R	NR	R	150°	R	–
Vegetable Oils	R	R	R	R	R	–
Vinegar	R	R	R	R	R	R
White Liquor, Pulp Mill	–	–	R	R	–	–

R = Recommended NR = Not recommended – = No information available

Note: The recommendations contained in this table (pages 9-10) are made without guarantee of representation as to results. Since the actual use by others is beyond our control, no guarantee, expressed or implied, is made by Champion Fiberglass as to effects of such use or results to be obtained nor does Champion Fiberglass assume any liability arising out of the use by others of the products referenced in this table (pages 9-10). Nor is the information herein to be construed as absolutely complete since additional information may be needed or desirable when particular or exceptional conditions or circumstances exist or because of applicable laws or government regulations. We suggest that you evaluate these recommendations and suggestions in your own laboratory prior to use. Our responsibility for claims arising from breach of warranty, negligence, or otherwise is limited to the purchase price of the material.

Channel

CHAMPION STRUT™ CS-S SERIES CHANNEL

The Champion Strut CS-S Series channel profile incorporates a unique flange design that provides positive interlocking and fastening of all non-metallic strut-related components. Champion Strut CS-S Series channel profile is designed to allow complete engagement and maximum pull-out strength of channel accessories. Flange design provides maximum strength compared to traditional fiberglass channel profile flange designs and permits greater torquing of accessories without failure. The Champion Strut CS-S Series channel profile is **not** designed to be used with traditional steel pipe clamps.

Materials

Channels are provided in two different resin systems, polyester and vinyl ester resin.

Polyester Resin

Polyester resin channels are provided in a dark grey color for CS-S Series channels. Polyester channel special colors are available upon request.

Vinyl Ester Resin

Vinyl ester resin channels are provided in beige color for both the CS-S Series channels. Vinyl ester channel special colors are available upon request.

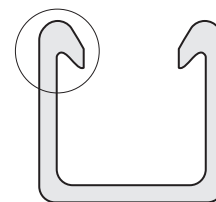

Champion Strut
Flange Design

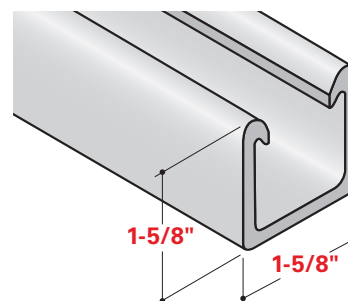

CHAMPION STRUT™ SST SERIES CHANNEL

The Champion Strut SST Series channel profile is designed strictly to be used with traditional steel pipe clamps. Champion Strut CS-SST Series channel profile is not designed to be used with any polyurethane channel accessories (channel nuts and pipe clamps) pictured in this catalog. The CS-SST Series channel flange design will not interlock correctly with these accessories causing potential failures.

Materials

Channels are provided in two different resin systems, polyester and vinyl ester resin.

Polyester Resin

Polyester resin channels are provided in a light grey color for CS-SST Series channels. Polyester channel special colors are available upon request.

Vinyl Ester Resin

Vinyl ester resin channels are provided in a beige color for the CS-SST Series channels. Vinyl ester channel special colors are available upon request.

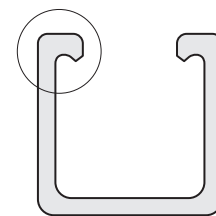

SST Flange

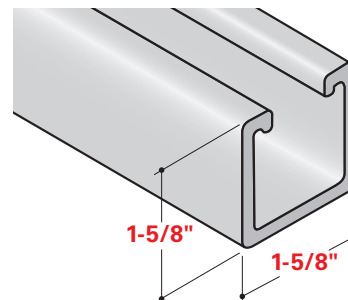

CHAMPION STRUT™ CONCRETE EMBEDMENT CHANNEL

In certain construction applications, it may become necessary to insert a fiberglass channel into a new pouring of concrete. Concrete embedment channel is designed to be cast in place, or inserted flush into wet concrete and allowed to fully cure. This provides a secure suitable mechanical anchor for items to be fastened into the channel.

Concrete embedment channel consists of the Champion Strut standard 1-5/8" x 1-5/8" channel (either Series CS-S or CS-SST channels) bonded to a continuous pultruded fiberglass flat bar (1/2" thick x 2-3/8" wide) with a high strength epoxy adhesive. Channel does not include foam insert (PN# CS-FI) or plastic closure strip (PN# CS-CS).

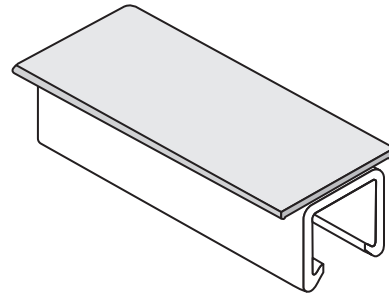
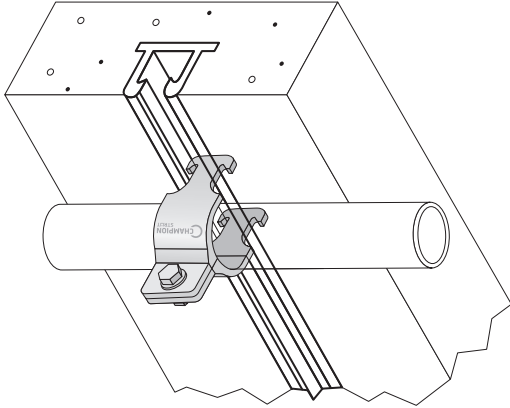

CSFI

Plastic foam insert for temporary use during concrete pour.

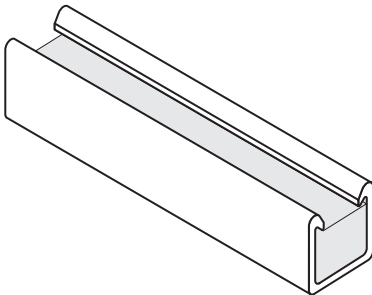

CSCS

Plastic closure strip.

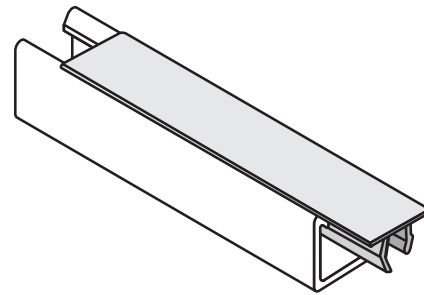

ITEM NO*	CHANNEL SERIES	LENGTH
CS-S-CI	1-5/8" x 1-5/8" S	10 ft
CS-SST-CI	1-5/8" x 1-5/8" SST	10 ft

* To specify polyester or vinyl ester, add suffix "-P" or "-V" to part number.

CHAMPION STRUT™ CHANNEL LOADING TYPES

When designing a Champion Strut support system, the following methods of loading must be considered:

- Beam
- Column
- Flange

BEAM LOADING

A beam is a structural element that primarily resists loads applied laterally to the beam's axis. Its mode of deflection is primarily by bending. The loads applied to the beam result in reaction forces at the beam's support points.

A typical Champion Strut™ trapeze hanger is an example of the most commonly seen beam-loading application. Refer to the Champion Strut Channel Loading chart (pages 16-17) to determine the beam loading for your application.

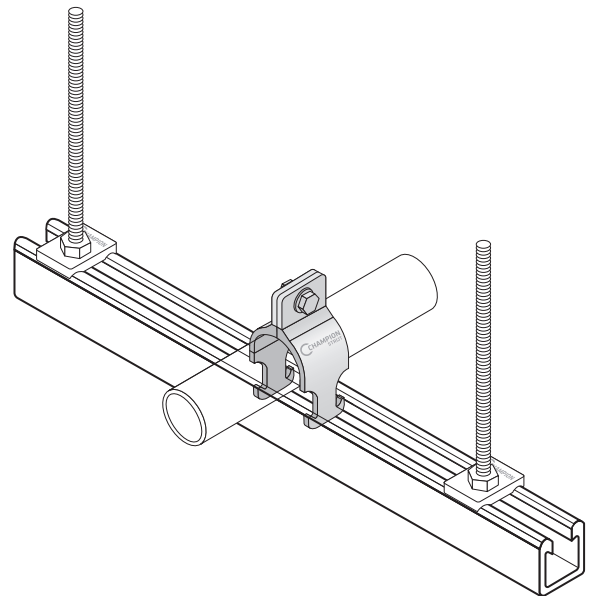
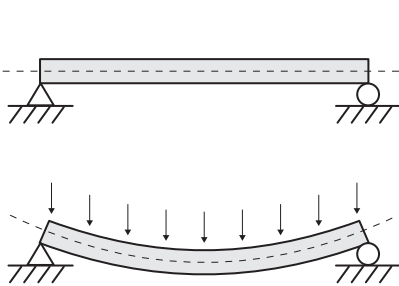

Trapeze Hanger

COLUMN LOADING

Columns are structural members that are loaded parallel to their length. Most columns are vertical and are used to carry loads from a higher level to a lower level.

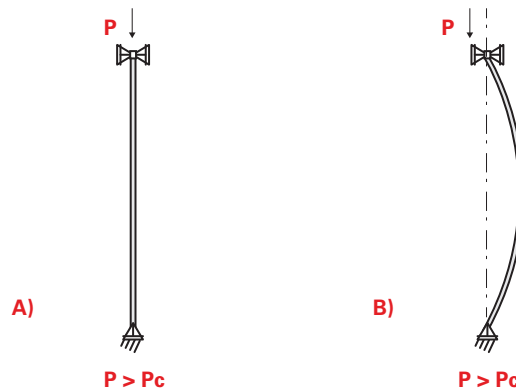

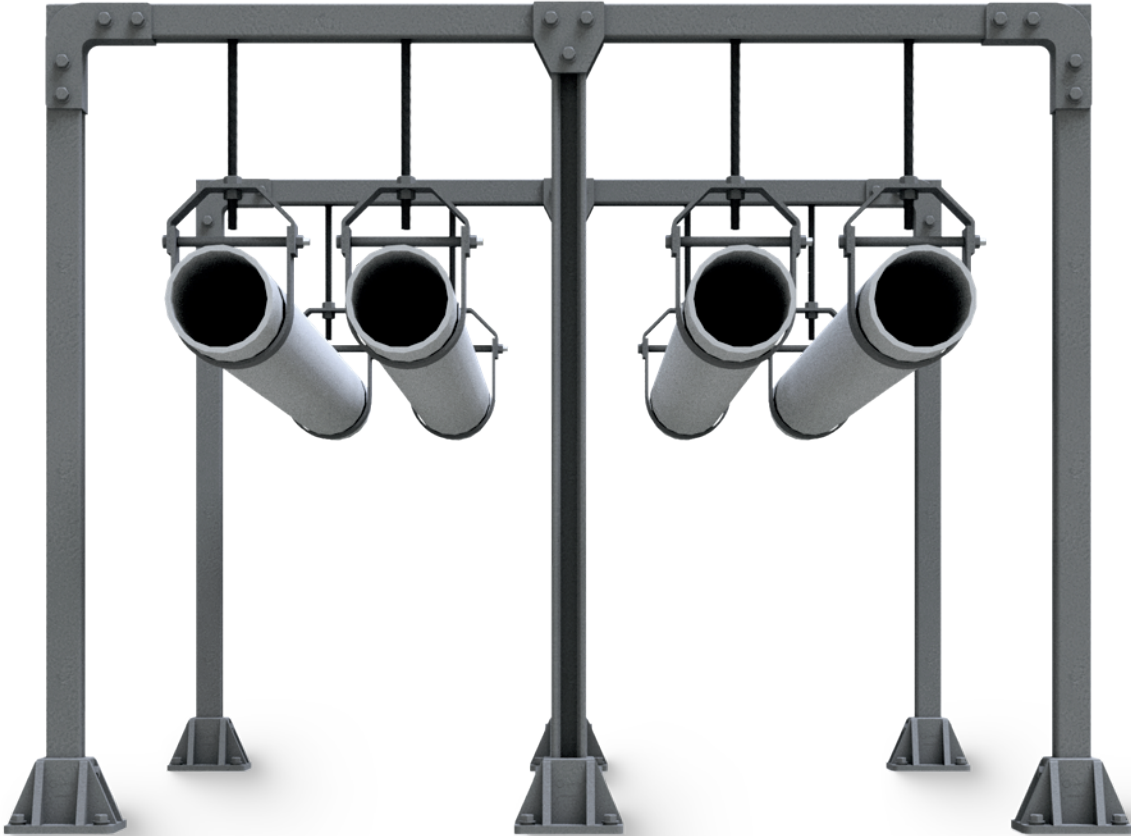

A typical Champion Strut™ pipe support is an example of the most commonly seen column-loading application. Refer to the Champion Strut Channel Loading chart (pages 16-17) to determine the column loading for your application.

FLANGE LOADING

Flange loading is the pull-out strength or resistance of the Champion Strut lips to tension from the accessories (pipe clamps or fasteners).

Flange Load



CHANNEL TYPE	SIZE	PULL-OUT STRENGTH (PSI)
CS-S Series Vinyl Ester	1-5/8" x 1-5/8"	450
CS-S Series Polyester	1-5/8" x 1-5/8"	360
CS-SST Vinyl Ester	1-5/8" x 1-5/8"	350
CS-SST Polyester	1-5/8" x 1-5/8"	300
CS-S Series Vinyl Ester	1-1/2" x 1-1/8"	210
CS-S Series Polyester	1-1/2" x 1-1/8"	210
CS-SST Vinyl Ester	1-5/8" x 1-1/8"	210
CS-SST Polyester	1-5/8" x 1-1/8"	210

* Values shown represent a 3:1 safety factor.

CHAMPION STRUT™ BEAM-LOADING CONVERSION TABLE

The following Champion Strut beam-loading conversion table shows the multipliers that should be used in conjunction with the Champion Strut beam-loading chart. This beam-loading conversion table can be used to convert the simple beam-loading information (pages 16-17) to one of the type loads below.

LOAD AND SUPPORT CONDITION	LOAD FACTOR	DEFLECTION FACTOR
1. Simple Beam, Uniform Load 	1.00	1.00
2. Simple Beam, Concentrated Load at Center 	0.50	0.80
3. Simple Beam, Two Equal Concentrated Loads at 1/4 pts 	1.00	1.10
4. Beam Fixed at Both Ends, Uniform Load 	1.50	0.30
5. Beam Fixed at Both Ends, Concentrated Load at Center 	1.00	0.40
6. Cantilever Beam, Uniform Load 	0.25	2.40
7. Cantilever Beam, Concentrated Load at End 	0.12	3.20
8. Continuous Beam, Two Equal Spans, Uniform Load on One Span 	1.30	0.92
9. Continuous Beam, Two Equal Spans, Uniform Load on Both Ends 	1.00	0.42
10. Continuous Beam, Two Equal Spans, Concentrated Load at Center of One Span 	0.62	0.71
11. Continuous Beam, Two Equal Spans, Concentrated Load at Center of Each Span 	0.67	0.48

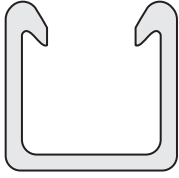

CS-S SERIES POLYESTER AND VINYL ESTER CHANNEL BEAM-LOADING CHART

SPAN		ITEM NO	MAXIMUM UNIFORM BEAM LOAD		MAXIMUM COLUMN LOAD
			LOAD (LBS)*	DEFLECTION (IN)	(LBS)**
12"	<input type="checkbox"/>	CS-S10-10P or V	1,629	0.151"	2,759
	<input type="checkbox"/>	CS-S20-10P or V	3,561	0.102"	5,160
	<input type="checkbox"/>	CS-S20D-10P or V	5,559	0.028"	9,454
18"	<input type="checkbox"/>	CS-S10-10P or V	1,086	0.340"	2,351
	<input type="checkbox"/>	CS-S20-10P or V	2,374	0.230"	4,704
	<input type="checkbox"/>	CS-S20D-10P or V	3,706	0.064"	8,866
24"	<input type="checkbox"/>	CS-S10-10P or V	815	0.605"	1,862
	<input type="checkbox"/>	CS-S20-10P or V	1,781	0.410"	4,168
	<input type="checkbox"/>	CS-S20D-10P or V	2,780	0.113"	8,181
30"	<input type="checkbox"/>	CS-S10-10P or V	652	0.945"	1,298
	<input type="checkbox"/>	CS-S20-10P or V	1,424	0.640"	3,553
	<input type="checkbox"/>	CS-S20D-10P or V	2,224	0.177"	7,405
36"	<input type="checkbox"/>	CS-S10-10P or V	543	1.360"	901
	<input type="checkbox"/>	CS-S20-10P or V	1,187	0.922"	2,859
	<input type="checkbox"/>	CS-S20D-10P or V	1,853	0.254"	6,451
48"	<input type="checkbox"/>	CS-S10-10P or V	407	2.418"	507
	<input type="checkbox"/>	CS-S20-10P or V	890	1.638"	1,636
	<input type="checkbox"/>	CS-S20D-10P or V	1,390	0.452"	4,534
60"	<input type="checkbox"/>	CS-S10-10P or V	326	3.779"	324
	<input type="checkbox"/>	CS-S20-10P or V	712	2.560"	1,047
	<input type="checkbox"/>	CS-S20D-10P or V	1,112	0.707"	2,902
72"	<input type="checkbox"/>	CS-S10-10P or V	272	5.441"	225
	<input type="checkbox"/>	CS-S20-10P or V	594	3.686"	727
	<input type="checkbox"/>	CS-S20D-10P or V	927	1.018"	2,015

* Beam loads based on a 2:1 safety factor

** Column loads based on a 3:1 safety factor

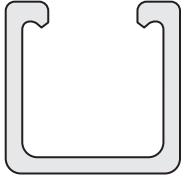

CS-SST SERIES POLYESTER AND VINYL ESTER CHANNEL BEAM-LOADING CHART

CHANNEL

SPAN		ITEM NO	MAXIMUM UNIFORM BEAM LOAD		DEFLECTION AT MAXIMUM UNIFORM BEAM LOAD		MAXIMUM COLUMN LOAD (LBS)**
			POLY (LBS)*	VINYL (LBS)*	POLY (IN)	VINYL (IN)	
12" Span	<input type="checkbox"/>	CS-SST11-10	790	990	0.11"	0.12"	2,550
	<input type="checkbox"/>	CS-SST11D-10	1,500	1,950	0.05"	0.06"	4,950
	<input type="checkbox"/>	CS-SST15-10	1,720	2,150	0.07"	0.07"	3,650
	<input type="checkbox"/>	CS-SST15D-10	5,080	6,350	0.04"	0.04"	7,300
18" Span	<input type="checkbox"/>	CS-SST11-10	530	670	0.24"	0.27"	2,350
	<input type="checkbox"/>	CS-SST11D-10	1,300	1,500	0.12"	0.14"	4,750
	<input type="checkbox"/>	CS-SST15-10	1,150	1,440	0.15"	0.17"	3,370
	<input type="checkbox"/>	CS-SST15D-10	5,080	4,240	0.09"	0.10"	6,740
24" Span	<input type="checkbox"/>	CS-SST11-10	400	500	0.43"	0.48"	2,070
	<input type="checkbox"/>	CS-SST11D-10	1,212	1,470	0.25"	0.27"	4,600
	<input type="checkbox"/>	CS-SST15-10	860	1,080	0.27"	0.30"	2,690
	<input type="checkbox"/>	CS-SST15D-10	2,540	3,130	0.16"	0.17"	5,920
30" Span	<input type="checkbox"/>	CS-SST11-10	320	400	0.67"	0.75"	1,730
	<input type="checkbox"/>	CS-SST11D-10	946	1,176	0.38"	0.42"	3,460
	<input type="checkbox"/>	CS-SST15-10	690	870	0.42"	0.48"	2,450
	<input type="checkbox"/>	CS-SST15D-10	2,040	2,550	0.24"	0.27"	4,900
36" Span	<input type="checkbox"/>	CS-SST11-10	270	340	0.98"	1.10"	1,260
	<input type="checkbox"/>	CS-SST11D-10	794	946	0.56"	0.61"	2,520
	<input type="checkbox"/>	CS-SST15-10	580	730	0.61"	0.69"	1,800
	<input type="checkbox"/>	CS-SST15D-10	1,700	2,130	0.35"	0.39"	3,600
48" Span	<input type="checkbox"/>	CS-SST11-10	200	250	1.72"	1.92"	700
	<input type="checkbox"/>	CS-SST11D-10	591	737	0.99"	1.10"	1,390
	<input type="checkbox"/>	CS-SST15-10	430	540	1.07"	1.20"	1,010
	<input type="checkbox"/>	CS-SST15D-10	1,270	1,590	0.62"	0.69"	2,020
60" Span	<input type="checkbox"/>	CS-SST11-10	160	200	2.68"	2.99"	180
	<input type="checkbox"/>	CS-SST11D-10	466	641	1.52"	1.70"	350
	<input type="checkbox"/>	CS-SST15-10	350	400	1.70"	1.91"	260
	<input type="checkbox"/>	CS-SST15D-10	1,020	1,280	0.97"	1.09"	520
72" Span	<input type="checkbox"/>	CS-SST11-10	140	180	–	–	–
	<input type="checkbox"/>	CS-SST11D-10	410	521	2.18"	2.48"	–
	<input type="checkbox"/>	CS-SST15-10	290	370	2.44"	2.78"	–
	<input type="checkbox"/>	CS-SST15D-10	850	1,070	1.40"	1.57"	–

* Beam loads based on a 2:1 safety factor

** Column loads based on a 3:1 safety factor

Deflection in excess of 3.00 in. (76mm): mid-span support is not recommended.

Notes: Beam Load table lists the total allowable load for various simple spans based on a minimum safety factor of 2:1. If load is concentrated at center of span, multiply the load from the table by 0.5 and the corresponding deflection by 0.8. Column Load table lists the total allowable axial load for various unsupported column heights based on a minimum safety factor of 3:1. Eccentric loads should be reduced according to standard practice.

All beams should be supported in a manner to prevent rotation at supports. Long deep beams should be tied between supports to prevent twist.



**CS-S SERIES HEAVY DUTY
1-5/8" CHANNEL PROFILE**

Solid
CS-S20-10P, CS-S20-10V

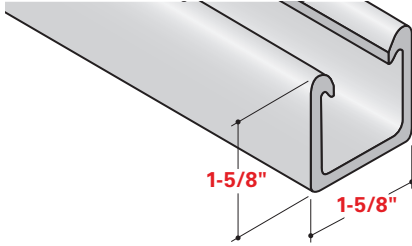

Slotted (1" x 3/8" holes on 2" centers)
CS-S20S-10P, CS-S20S-10V

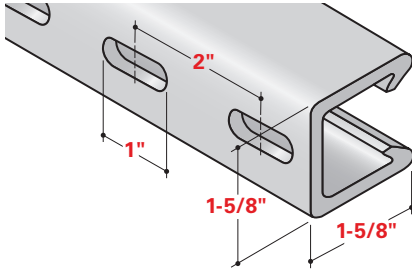

Back-to-back
CS-S20D-10P, CS-S20D-10V

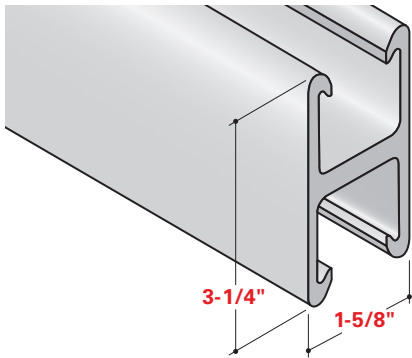

With concrete inserts
CS-S20CI-10P, CS-S20CI-10V

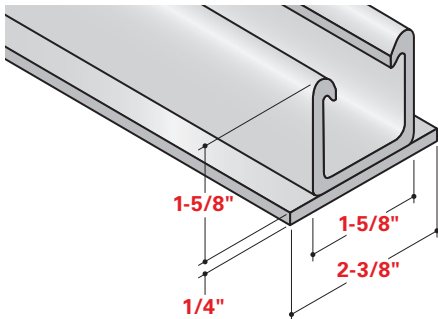

**CS-S SERIES HEAVY DUTY SHALLOW
CHANNEL PROFILE**

Solid
CS-S10-10P, CS-S10-10V

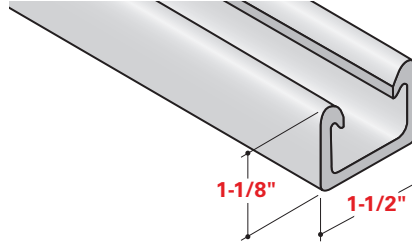

Slotted (1" x 3/8" holes on 2" centers)
CS-S10S-10P, CS-S10S-10V

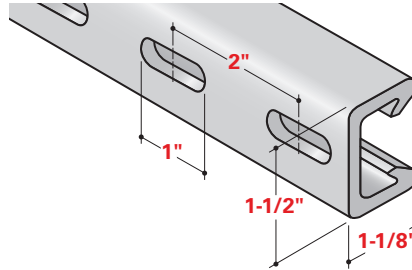

Back-to-back
CS-S10D-10P, CS-S10D-10V

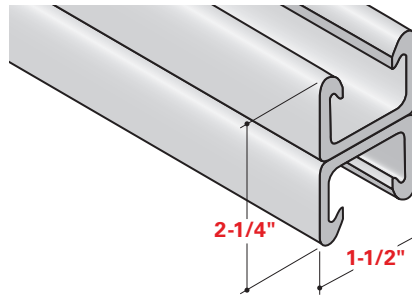

CSFI

Plastic foam insert
for temporary use
during concrete pour.

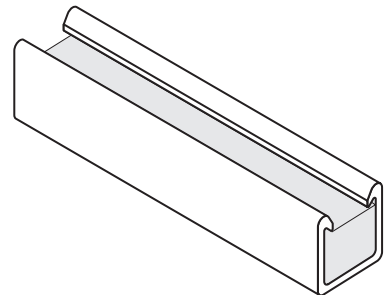

CS-SST SERIES CHANNEL – STANDARD DUTY PROFILE

Solid

CS-SST-15-10P, CS-SST-15-10V

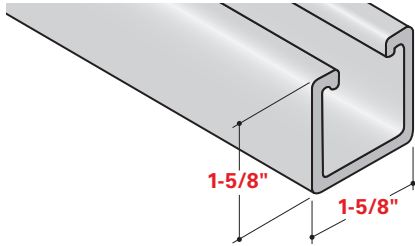

Slotted (1" x 3/8" holes on 2" centers)

CS-SST-15S-10P, CS-SST-15S-10V

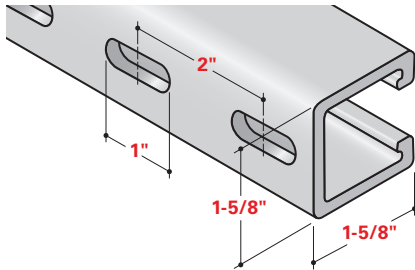

Back-to-back

CS-SST15D-10P, CS-SST15D-10V

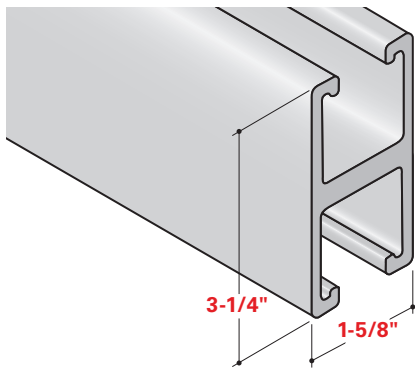

With concrete inserts

CS-SST-15CI-10P, CS-SST-15CI-10V

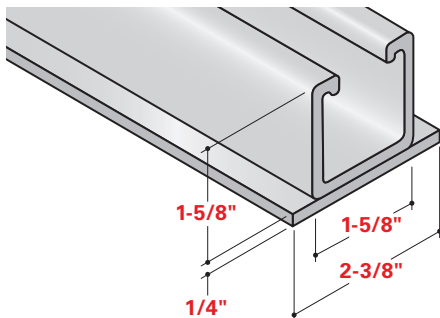

CS-SST SERIES SHALLOW CHANNEL PROFILE

Solid

CS-SST11-10P, CS-SST11-10V

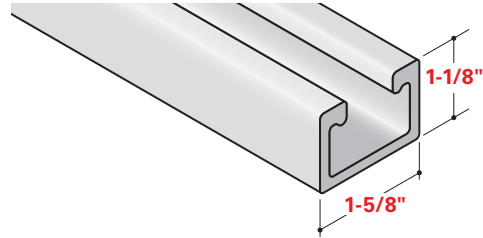

Slotted (1" x 3/8" holes on 2" centers)

CS-SST11S-10P, CS-SST11S-10V

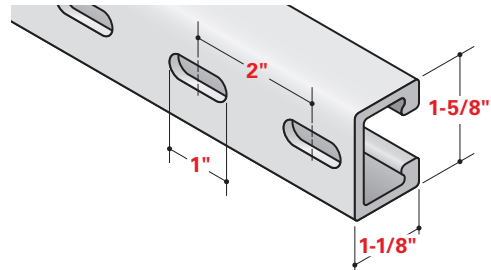

Back-to-back

CS-SST11D-10P, CS-SST11D-10V

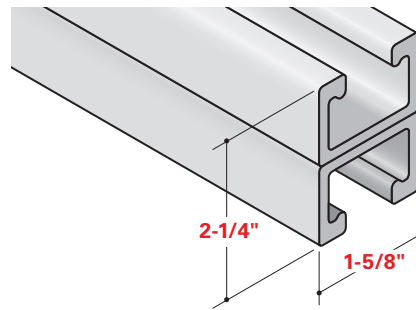

CHAMPION STRUT™ CHANNEL CLOSURE STRIP

PVC closure strip is designed to close and provide a cover for the channel opening. Channel closure strip is provided in 5-ft lengths and is easily installed by pressing it into the channel opening.

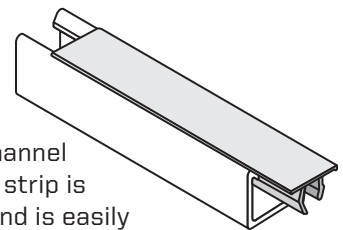

	ITEM NO	LENGTH
<input type="checkbox"/>	CS-CS-5	5 ft

Closure strip fits both CS-S and CS-SST series channels



Channel Fittings

Champion Strut™ channel fittings are required to fabricate any pipe support or pipe supporting structure. The channel fittings are easily attached to Champion Strut channels with channel nuts and polyurethane hardware fasteners. Champion Strut fittings are offered in two types; fabricated (cut from 3/8" thick, flat polyester or vinyl ester fiberglass sheet stock) or injection molded from glass-reinforced polyurethane. Polyester channel fittings are provided in a dark grey color and vinyl ester channel fittings are provided in beige color. Polyurethane channel fittings are provided in a dark grey color and can be used with polyester or vinyl ester channels. All channel fittings are provided with 13/32" hole sizing to accommodate 3/8" hardware. If larger diameter hardware hole sizing is required, the channel fittings can easily be drilled out with a carbide-tipped drill bit to accommodate the desired size hardware hole.

-P suffix fittings (polyester) are grey.

-V suffix fittings (vinyl ester) are beige.

No suffix fittings (polyurethane) are grey.

CS-2502P, CS-2502V

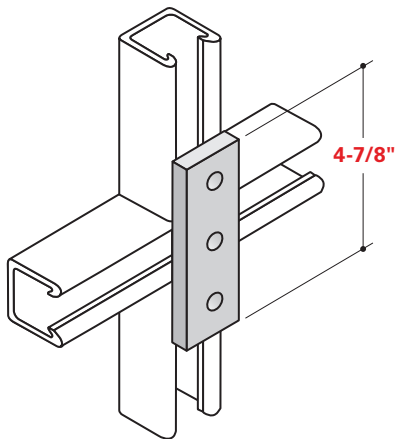

CS-2500P, CS-2500V

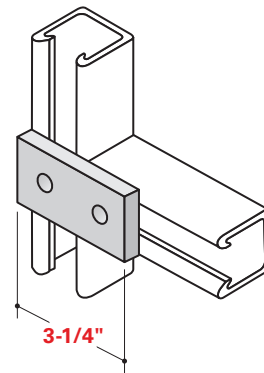

CS-2504P, CS-2504V

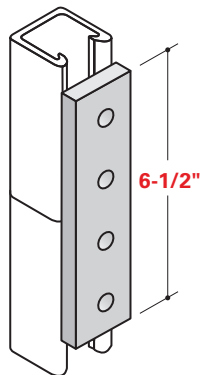

CS-2506P, CS-2506V

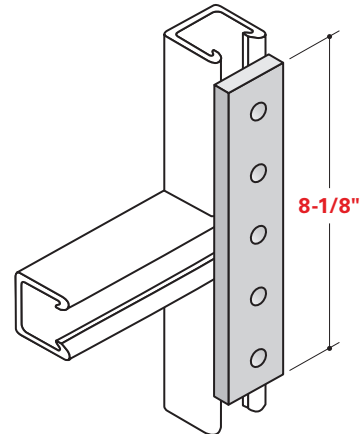

CS-2508P, CS-2508V

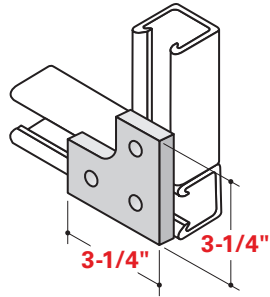

CS-2512P, CS-2512V

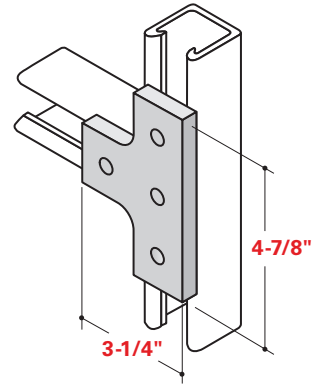

CS-2518P, CS-2518V

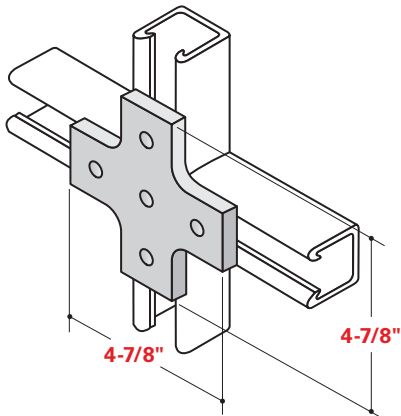

CS-2514P, CS-2514V

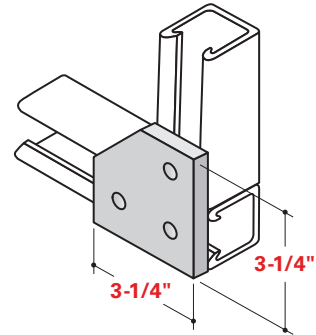

CS-2510P, CS-2510V

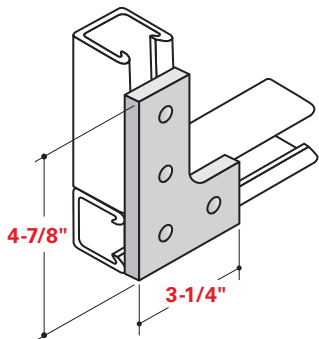

CS-2516P, CS-2516V

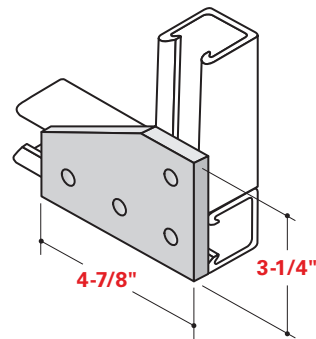

CS-2522P, CS-2522V

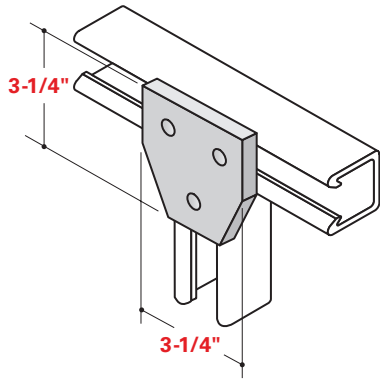

CS-2524P, CS-2524V

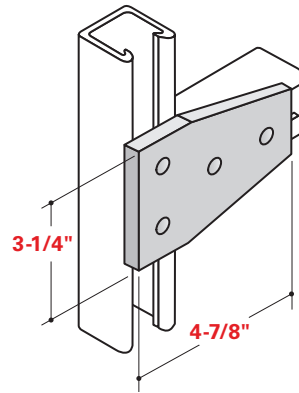

CS-2526P, CS-2526V

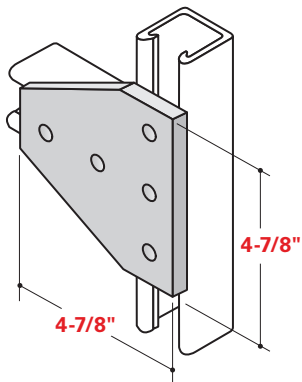

CS-2530P, CS-2530V

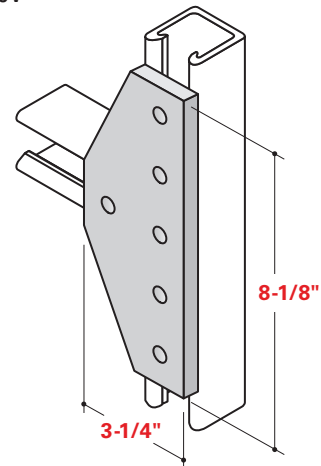

CS-2534P, CS-2534V

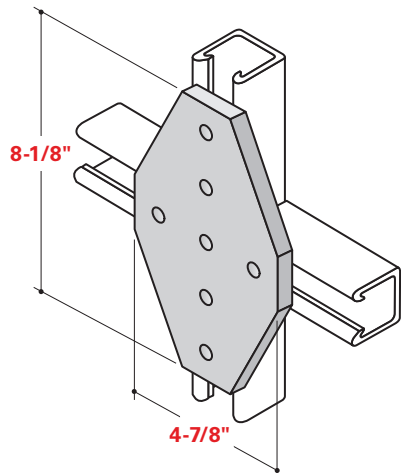

CS-121

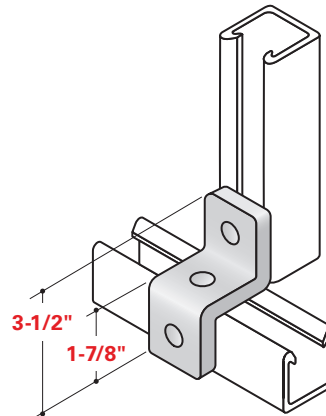

CS-2520P, CS-2520V

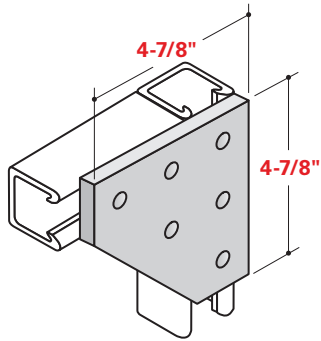

CS-2528P, CS-2528V

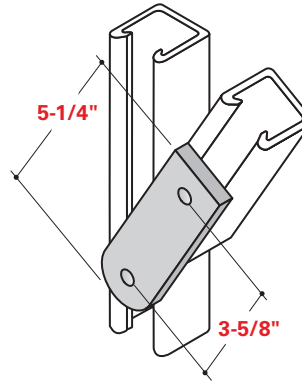

CS-126

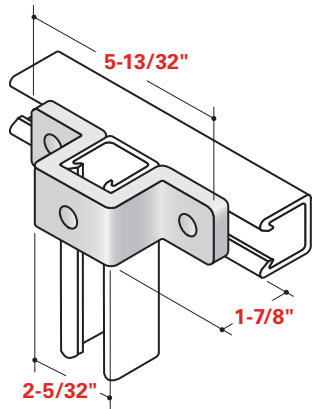

CS-127

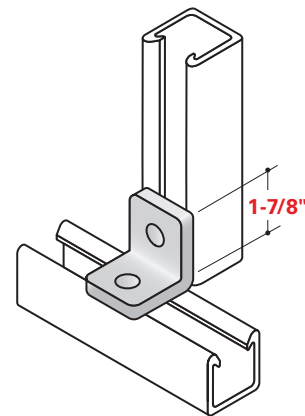

CS-2540P, CS-2540V

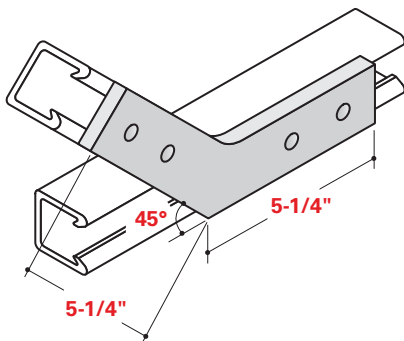

CS-130

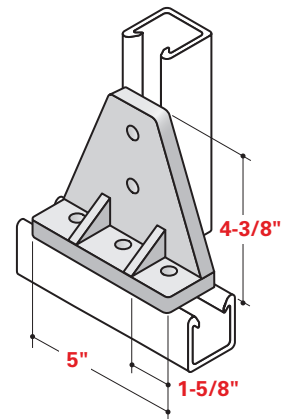

CS-132

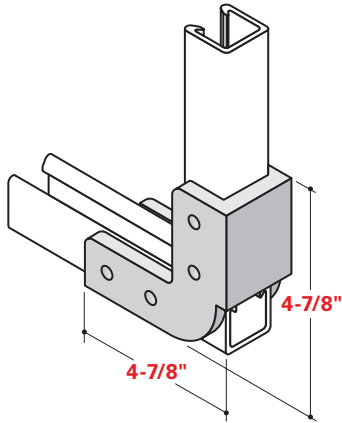

CS-133

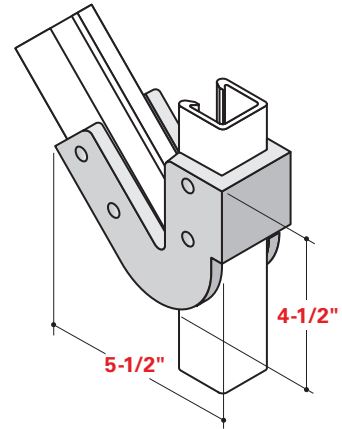

CS-134

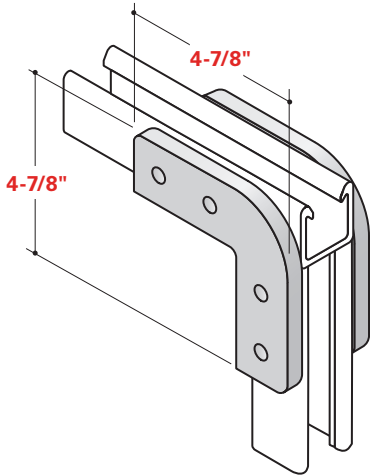

CS-135

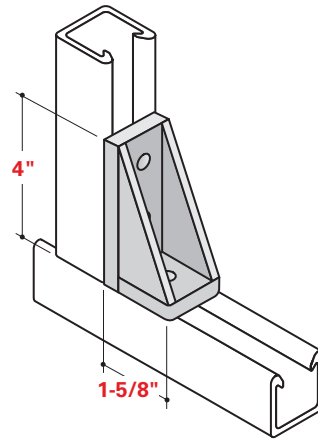

CS-200

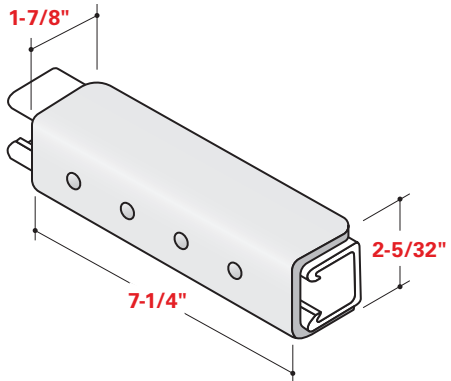

CS-2542P, CS-2542V

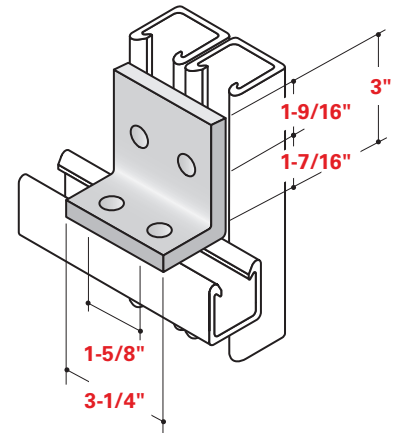

CS-2541P, CS-2541V

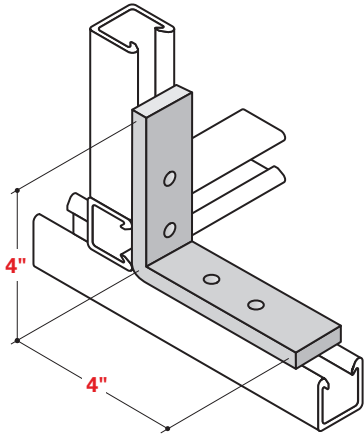

CS-PB-20S (1-5/8" x 1-5/8"), CS-PB-10S (1-1/8" x 1-1/2")

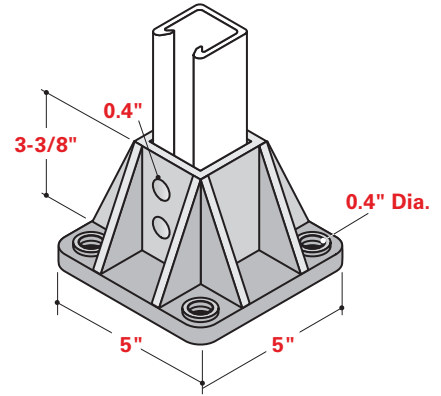

CS-PB-20D (1-5/8" x 3-1/4"), CS-PB-10D (1-1/8" x 2-1/4")

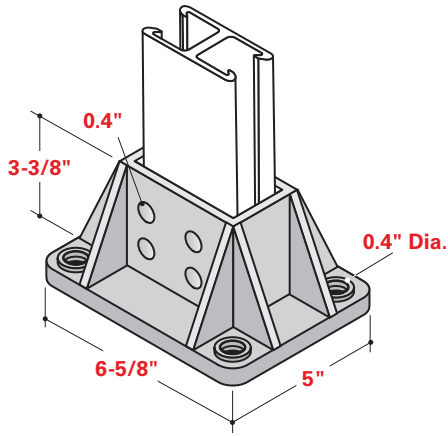

Pipe Clamps

CHAMPION STRUT™ PIPE CLAMP DESIGN LOAD DATA

Care should be taken to recognize the two different piping system loadings, overhead (Type 1) and vertical (Type 2). Champion Strut pipe clamps show the recommended loading for each type of application.

Type 1 Design Loading

Type 1 Design Loading represents piping being supported overhead below the channel. The design loads shown represent a 3:1 safety factor.

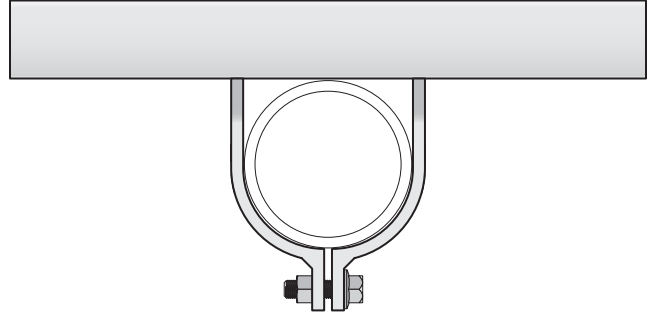

Type 2 Design Loading

Type 2 Design Loading represents piping being supported with the addition of a physical “Stop-Lock Assembly” (CS-SL-500) which assists in prohibiting slippage of the vertically supported piping within the channel. The “Stop-Lock” should be installed directly beneath the pipe clamp as illustrated. It is recommended the “Stop-Lock Assembly” be used for all vertical piping applications. The design loads shown represent a 3:1 safety factor.

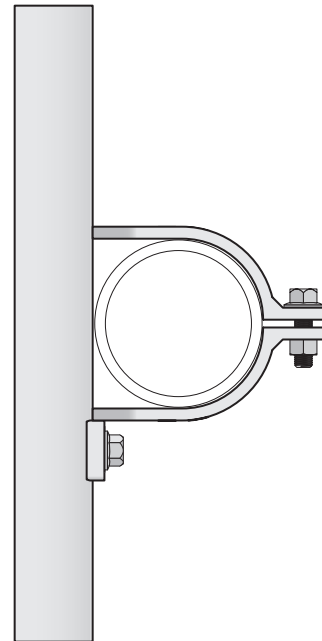

CHAMPION STRUT™ RIGID PIPE CLAMPS

Champion Strut rigid pipe clamps are made from glass-reinforced polyurethane and are IPS-sized to fit the OD (outside diameter) of SCH40 and SCH80 PVC piping and conduit as well as IPS-sized steel piping and steel/fiberglass conduits. The Champion Strut rigid clamps are designed to be used within (and not to exceed) operating temperatures up to 160°F. Care should be taken not to exceed the recommended torque values shown.

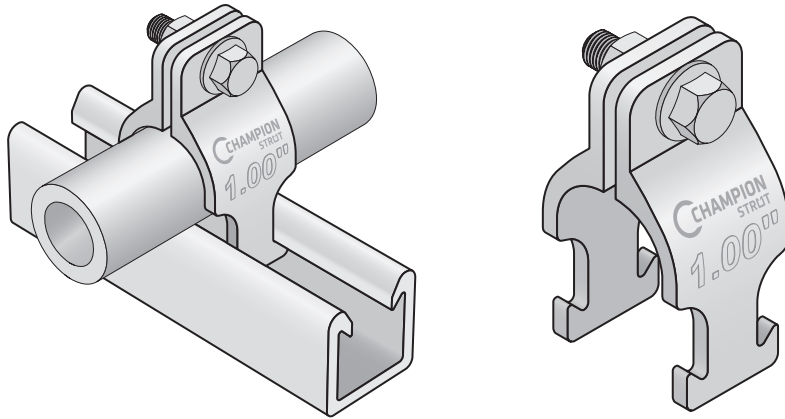

	ITEM NO	NOMINAL SIZE (IN)	IPS PIPING SIZE (IN)	DESIGN LOADS (LBS)		FRP BOLT SIZE (IN)	FRP BOLT TORQUE (FT/LBS)
				TYPE 1	TYPE 2		
<input type="checkbox"/>	CS-PC-050	1/2"	0.84"	226	91	3/8" x 1-1/4"	3
<input type="checkbox"/>	CS-PC-075	3/4"	1.05"	226	91	3/8" x 1-1/4"	3
<input type="checkbox"/>	CS-PC-100	1"	1.32"	226	91	3/8" x 1-1/4"	3
<input type="checkbox"/>	CS-PC-125	1-1/4"	1.66"	226	91	3/8" x 1-1/4"	3
<input type="checkbox"/>	CS-PC-150	1-1/2"	1.90"	226	91	3/8" x 1-1/4"	3
<input type="checkbox"/>	CS-PC-200	2"	2.37"	226	91	3/8" x 1-1/4"	3
<input type="checkbox"/>	CS-PC-250	2-1/2"	2.87"	226	91	3/8" x 1-1/4"	3
<input type="checkbox"/>	CS-PC-300	3"	3.50"	226	91	3/8" x 1-1/4"	3
<input type="checkbox"/>	CS-PC-400	4"	4.50"	301	126	3/8" x 1-1/4"	3
<input type="checkbox"/>	CS-PC-500	5"	5.56"	301	126	3/8" x 1-1/4"	3
<input type="checkbox"/>	CS-PC-600	6"	6.63"	301	126	3/8" x 1-1/4"	3
<input type="checkbox"/>	CS-PC-800	8"	8.63"	301	126	3/8" x 1-1/4"	3

Note: Design loads indicated represent a 3:1 safety factor. Torque value displayed is in ft/lbs. Pipe clamps are supplied with 3/8" nut and bolt hardware.

CHAMPION STRUT™ TWO-HOLE PIPE CLAMPS

Champion Strut two-hole pipe clamps are designed for securing IPS-sized piping and conduit to Champion Strut channels or other material type channels. These two-hole pipe clamps can be used in both Type 1 and Type 2 loading applications. The Champion Strut two-hole pipe clamps are manufactured from a fire-retardant, glass-reinforced polyester resin. Larger diameter clamps for special applications are also available. Please contact the Champion Fiberglass factory for pricing and availability on vinyl ester hangers and non-standard pipe clamp sizes.

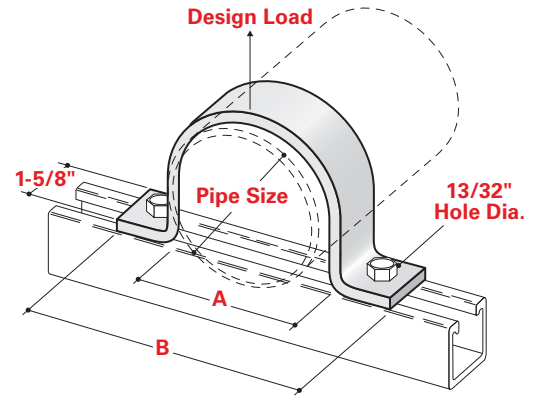

	ITEM NO	NOMINAL SIZE (IN)	IPS PIPING SIZE (IN)	BOLT SIZE (IN)	DESIGN LOAD		DIMENSIONS		MATERIAL SIZE (IN)	FRP BOLT TORQUE (FT/LBS)
					TYPE 1 (LBS)	TYPE 2 (LBS)	A (IN)	B (IN)		
<input type="checkbox"/>	CS-PS-050	1/2"	.84"	1/2"	135	50	.84"	4.84"	1/4" x 1-5/8"	4
<input type="checkbox"/>	CS-PS-075	3/4"	1.05"	1/2"	135	50	1.05"	5.05"	1/4" x 1-5/8"	4
<input type="checkbox"/>	CS-PS-100	1"	1.32"	1/2"	135	50	1.32"	5.32"	1/4" x 1-5/8"	4
<input type="checkbox"/>	CS-PS-150	1-1/2"	1.90"	1/2"	135	50	1.90"	5.90"	1/4" x 1-5/8"	4
<input type="checkbox"/>	CS-PS-200	2"	2.37"	1/2"	135	50	2.375"	6.375"	1/4" x 1-5/8"	4
<input type="checkbox"/>	CS-PS-250	2-1/2"	2.87"	1/2"	135	50	2.875"	6.875"	1/4" x 1-5/8"	4
<input type="checkbox"/>	CS-PS-300	3"	3.50"	1/2"	135	50	3.50"	7.50"	1/4" x 1-5/8"	4
<input type="checkbox"/>	CS-PS-350	3-1/2"	4.00"	1/2"	135	50	4.00"	8.00"	1/4" x 1-5/8"	4
<input type="checkbox"/>	CS-PS-400	4"	4.50"	1/2"	175	60	4.50"	8.50"	1/4" x 1-5/8"	4
<input type="checkbox"/>	CS-PS-500	5"	5.56"	1/2"	175	60	5.563"	9.563"	1/4" x 1-5/8"	4
<input type="checkbox"/>	CS-PS-600	6"	6.63"	1/2"	175	60	6.625"	10.625"	1/4" x 1-5/8"	4
<input type="checkbox"/>	CS-PS-800	8"	8.63"	1/2"	225	125	8.625"	12.625"	1/4" x 1-5/8"	4
<input type="checkbox"/>	CS-PS-1000	10"	10.75"	5/8"	225	125	10.75"	15.75"	1/4" x 1-5/8"	10
<input type="checkbox"/>	CS-PS-1200	12"	12.75"	5/8"	225	125	12.75"	16.25"	1/4" x 1-5/8"	10
<input type="checkbox"/>	CS-PS-1400	14"	14.00"	5/8"	250	150	14.00"	18.00"	3/8" x 1-5/8"	10
<input type="checkbox"/>	CS-PS-1600	16"	16.00"	5/8"	250	150	16.00"	20.00"	3/8" x 1-5/8"	10
<input type="checkbox"/>	CS-PS-1800	18"	18.00"	5/8"	250	150	18.00"	23.00"	3/8" x 1-5/8"	10

Note: Design loads indicated represent a 3:1 safety factor. Two-hole pipe straps should not be torqued above recommended values. Torque values displayed are in ft/lbs.

CHAMPION STRUT™ CHANNEL END-CAPS

PVC channel end-caps are available for the CS-S and CS-SST series channels sized 1-5/8" x 3-1/4" (back-to-back) and 1-5/8" x 1-5/8" (single). These end-caps are available in black, white or red colors.

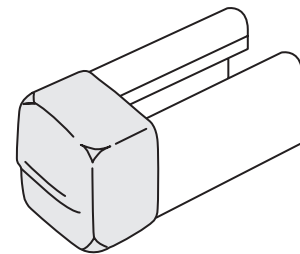

	ITEM NO	CHANNEL SIZE	COLOR
<input type="checkbox"/>	CS-EC-D-B	1-5/8" x 3-1/4"	Black
<input type="checkbox"/>	CS-EC-D-W	1-5/8" x 3-1/4"	White
<input type="checkbox"/>	CS-EC-D-R	1-5/8" x 3-1/4"	Red
<input type="checkbox"/>	CS-EC-S-B	1-5/8" x 1-5/8"	Black
<input type="checkbox"/>	CS-EC-S-W	1-5/8" x 1-5/8"	White
<input type="checkbox"/>	CS-EC-S-R	1-5/8" x 1-5/8"	Red

CHAMPION STRUT™ U-BOLTS

Champion Strut U-bolts provide a non-metallic composite alternative to traditional metallic U-bolts. Champion Strut U-bolts are available in standard and extended-reach sizes. All Champion Strut U-bolts are constructed from glass-reinforced polyurethane resin and are recommended for temperatures ranging from -40°F to +150°F. Each U-bolt is supplied with two polyurethane hex nuts. Additional nuts and washers can be purchased separately.

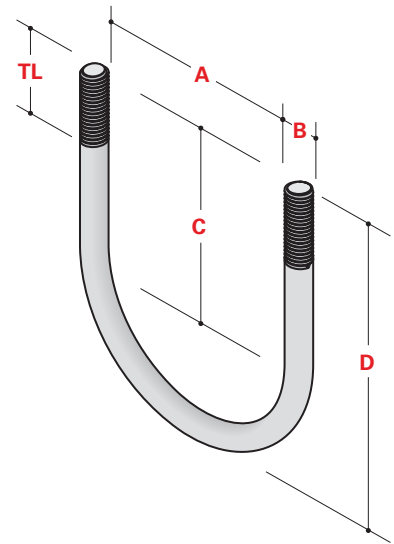

	ITEM NO	PIPE NOMINAL DIAMETER (IN)	DIMENSIONS					LOAD RATINGS	
			A (IN)	B (IN)	C (IN)	D (IN)	TL (IN)	MAX REC. LOAD LBS	MAX REC. LOAD IN/LBS
<input type="checkbox"/>	CS-UB-050	1/2"	0.93"	0.375"	1.56"	2.41"	1.25"	75	20
<input type="checkbox"/>	CS-UB-075	3/4"	1.12"	0.375"	1.66"	2.60"	1.25"	75	20
<input type="checkbox"/>	CS-UB-100	1"	1.37"	0.375"	1.78"	2.85"	1.25"	75	20
<input type="checkbox"/>	CS-UB-125	1-1/4"	1.68"	0.375"	1.94"	3.16"	1.25"	75	20
<input type="checkbox"/>	CS-UB-150	1-1/2"	2.00"	0.375"	2.10"	3.47"	1.25"	75	20
<input type="checkbox"/>	CS-UB-200	2"	2.43"	0.500"	2.46"	4.18"	1.50"	75	20
<input type="checkbox"/>	CS-UB-250	2-1/2"	2.93"	0.500"	2.71"	4.68"	1.50"	75	20
<input type="checkbox"/>	CS-UB-300	3"	3.56"	0.500"	3.03"	5.31"	1.50"	75	20
<input type="checkbox"/>	CS-UB-350	3-1/2"	4.06"	0.500"	3.28"	5.81"	1.50"	75	20
<input type="checkbox"/>	CS-UB-400	4"	4.56"	0.500"	3.53"	6.31"	1.50"	75	20

Note: Design loads indicated represent a 3:1 safety factor. U-bolts should not be torqued above recommended values. Torque values displayed are in in/lbs.

CHAMPION STRUT™ CHANNEL CLOSURE STRIP

PVC closure strip is designed to close and provide a cover for the channel opening. Channel closure strip is provided in 5-ft lengths and is easily installed by pressing it into the channel opening.

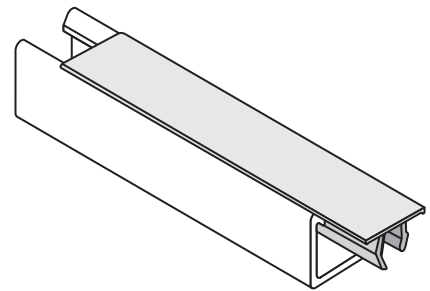

	ITEM NO	LENGTH
<input type="checkbox"/>	CS-CS-5	5 ft

Closure strip fits both CS-S and CS-SST series channels

CHAMPION STRUT™ EXTENDED-REACH U-BOLTS

Champion Strut extended-reach U-bolts provide a larger saddle area and longer threaded area than traditional metallic U-bolts. All extended-reach U-bolts are constructed from glass-reinforced polyurethane resin and are recommended for temperatures ranging from -40°F to +150°F. Each U-bolt is supplied with two polyurethane hex nuts. Additional nuts and washers can be purchased separately.

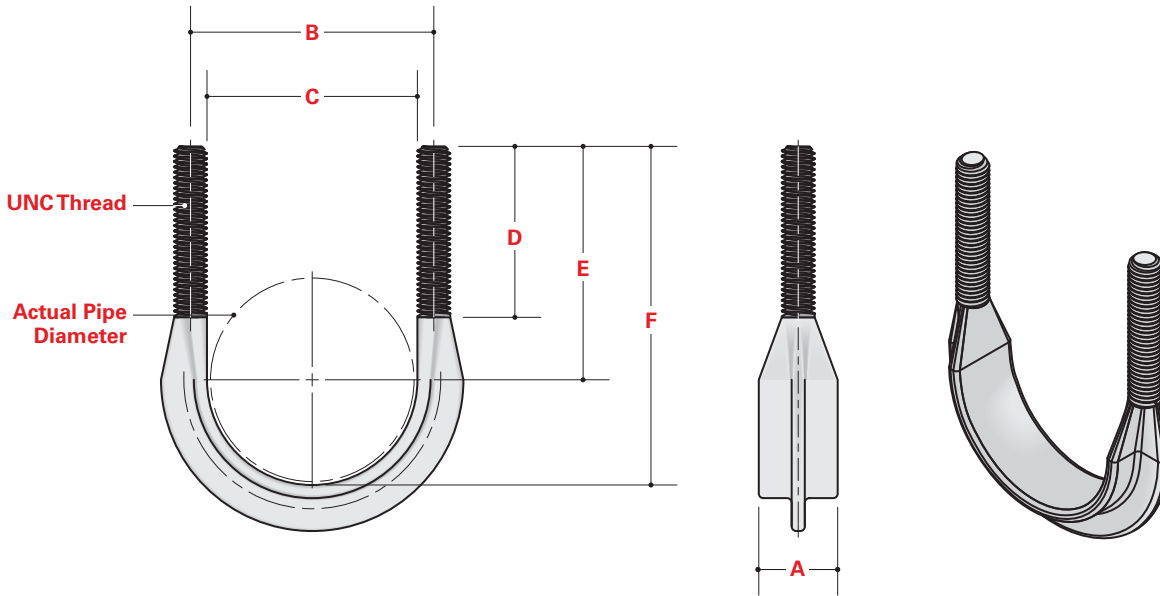

	ITEM NO	NOMINAL SIZE (IN)	IPS PIPING SIZE	DESIGN LOAD		UNC THREAD SIZE	FRP BOLT TORQUE (IN/LBS)
				TYPE 1 (LBS)	TYPE 2 (LBS)		
<input type="checkbox"/>	CS-UBE-100	1"	1.32"	300	150	3/8" – 16	40
<input type="checkbox"/>	CS-UBE-150	1-1/2"	1.90"	300	150	3/8" – 16	40
<input type="checkbox"/>	CS-UBE-200	2"	2.37"	300	150	1/2" – 13	80
<input type="checkbox"/>	CS-UBE-300	3"	3.50"	500	250	1/2" – 13	80
<input type="checkbox"/>	CS-UBE-400	4"	4.50"	500	250	1/2" – 13	80
<input type="checkbox"/>	CS-UBE-600	6"	6.625"	500	250	5/8" – 11	80

	ITEM NO	NOMINAL SIZE (IN)	DIMENSIONS							UNC THREAD SIZE	FRP BOLT TORQUE (IN/LBS)
			A (IN)	B (IN)	C (IN)	D (IN)	E (IN)	F (IN)	G (IN)		
<input type="checkbox"/>	CS-UBE-100	1"	.563"	1.75"	1.375"	1.875"	2.938"	3.00"	3.375"	3/8" – 16	40
<input type="checkbox"/>	CS-UBE-150	1-1/2"	.563"	2.375"	2.00"	2.125"	2.656"	3.656"	4.03"	3/8" – 16	40
<input type="checkbox"/>	CS-UBE-200	2"	.75"	2.938"	2.438"	2.375"	4.375"	5.593"	6.093"	1/2" – 13	80
<input type="checkbox"/>	CS-UBE-300	3"	.75"	4.125"	3.625"	2.625"	5.50"	7.313"	7.813"	1/2" – 13	80
<input type="checkbox"/>	CS-UBE-400	4"	.75"	5.125"	4.625"	2.625"	6.50"	8.513"	9.313"	1/2" – 13	80
<input type="checkbox"/>	CS-UBE-600	6"	.875"	7.375"	6.75"	3.25"	9.125"	12.313"	12.938"	5/8" – 11	80

Note: Design loads indicated represent a 3:1 safety factor. U-bolts should not be torqued above recommended values. Torque values displayed are in in/lbs.



Fasteners

CHAMPION STRUT™ FIBERGLASS-REINFORCED POLYURETHANE HARDWARE

Champion Strut fiberglass-reinforced hardware is manufactured from glass-reinforced polyurethane resin. Polyurethane is a superior grade, corrosion-resistant thermoplastic material that displays exceptional physical properties including toughness, flexibility and resistance to abrasion and temperature. Polyurethane resins exhibit impressive hardness and can be manufactured to be bowling ball hard. Polyurethane combines the toughness of metal with the elasticity of rubber. Parts made from fiberglass reinforced polyurethane resins often outlast rubber, wood and metals by 20 to 1. Additional glass-reinforced polyurethane benefits include extreme resistance to repeated bending without fracture, high load-bearing capacity and outstanding resistance to weather, ozone, radiation, oil, gasoline and many solvents.

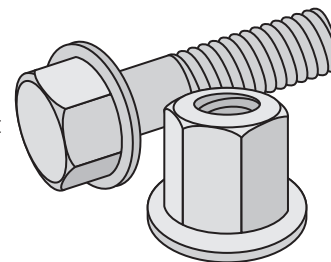

CHAMPION STRUT™ FIBERGLASS-REINFORCED POLYURETHANE BOLTS

Champion Strut fiberglass-reinforced bolts are available in two styles; hex head flange and hex head cap screw. The hex head flange bolts incorporate a molded washer collar flange that equally distributes torque pressure where the hex flange bolt head meets the mating surface thereby eliminating the need for a separate washer and minimizing the need for additional hardware.

FIBERGLASS-REINFORCED POLYURETHANE HEX FLANGE BOLTS

Fiberglass-reinforced hex flange bolts are available in sizes from 1/4" diameter through 1/2" diameter. Hex flange bolts are packaged in bags containing 25 pieces.

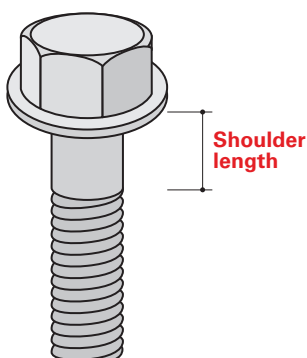

	ITEM NO	BOLT SIZE (IN)	SHOULDER LENGTH (IN)*	THREAD SHEAR (LBS)	SHANK SHEAR (LBS)	TORQUE*
<input type="checkbox"/>	CS-FB-250-075	1/4" x 3/4"	Full thread	110	210	10**
<input type="checkbox"/>	CS-FB-250-100	1/4" x 1"	Full thread	110	210	10**
<input type="checkbox"/>	CS-FB-250-150	1/4" x 1-1/2"	1/2"	110	210	10**
<input type="checkbox"/>	CS-FB-375-100	3/8" x 1"	Full thread	250	470	3*
<input type="checkbox"/>	CS-FB-375-125	3/8" x 1-1/4"	Full thread	250	470	3*
<input type="checkbox"/>	CS-FB-375-150	3/8" x 1-1/2"	Full thread	250	470	3*
<input type="checkbox"/>	CS-FB-375-200	3/8" x 2"	1/2"	250	470	3*
<input type="checkbox"/>	CS-FB-375-250	3/8" x 2-1/2"	3/4"	250	470	3*
<input type="checkbox"/>	CS-FB-375-300	3/8" x 3"	1"	250	470	3*
<input type="checkbox"/>	CS-FB-500-100	1/2" x 1"	Full thread	450	870	8*
<input type="checkbox"/>	CS-FB-500-125	1/2" x 1-1/4"	Full thread	450	870	8*
<input type="checkbox"/>	CS-FB-500-150	1/2" x 1-1/2"	Full thread	450	870	8*
<input type="checkbox"/>	CS-FB-500-200	1/2" x 2"	Full thread	450	870	8*
<input type="checkbox"/>	CS-FB-500-250	1/2" x 2-1/2"	Full thread	450	870	8*
<input type="checkbox"/>	CS-FB-500-300	1/2" x 3"	1/2"	450	870	8*
<input type="checkbox"/>	CS-FB-500-350	1/2" x 3-1/2"	1"	450	870	8*

* Torque values displayed are in ft/lbs unless noted otherwise.

** Torque values displayed are in/lbs.

Values shown represent a 3:1 safety factor.



FIBERGLASS-REINFORCED POLYURETHANE HEX HEAD CAP SCREWS

Fiberglass reinforced hex head cap screws are available in sizes 5/16", 3/8", 1/2" and 5/8" diameters. Hex head cap screws are packaged in bags containing 25 pieces.

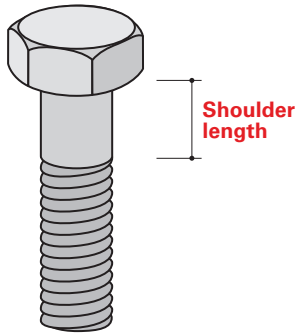

	ITEM NO	BOLT SIZE (IN)	SHOULDER LENGTH (IN)*	THREAD SHEAR (LBS)	SHANK SHEAR (LBS)	TORQUE*
<input type="checkbox"/>	CS-HB-312-100	5/16" x 1"	Full thread	250	470	3
<input type="checkbox"/>	CS-HB-312-125	5/16" x 1-1/4"	Full thread	250	470	3
<input type="checkbox"/>	CS-HB-312-150	5/16" x 1-1/2"	1/4"	250	470	3
<input type="checkbox"/>	CS-HB-312-200	5/16" x 2"	1/2"	250	470	3
<input type="checkbox"/>	CS-HB-375-100	3/8" x 1"	Full thread	250	470	3
<input type="checkbox"/>	CS-HB-375-125	3/8" x 1-1/4"	Full thread	250	470	3
<input type="checkbox"/>	CS-HB-375-150	3/8" x 1-1/2"	Full thread	250	470	3
<input type="checkbox"/>	CS-HB-375-200	3/8" x 2"	3/8"	250	470	3
<input type="checkbox"/>	CS-HB-375-250	3/8" x 2-1/2"	3/4"	250	470	3
<input type="checkbox"/>	CS-HB-375-300	3/8" x 3"	1"	250	470	3
<input type="checkbox"/>	CS-HB-500-100	1/2" x 1"	Full thread	450	870	8
<input type="checkbox"/>	CS-HB-500-125	1/2" x 1-1/4"	Full thread	450	870	8
<input type="checkbox"/>	CS-HB-500-150	1/2" x 1-1/2"	1/4"	450	870	8
<input type="checkbox"/>	CS-HB-500-200	1/2" x 2"	1/2"	450	870	8
<input type="checkbox"/>	CS-HB-500-250	1/2" x 2-1/2"	3/4"	450	870	8
<input type="checkbox"/>	CS-HB-500-300	1/2" x 3"	1"	450	870	8
<input type="checkbox"/>	CS-HB-625-125	5/8" x 1-1/4"	Full thread	700	1,360	12
<input type="checkbox"/>	CS-HB-625-150	5/8" x 1-1/2"	Full thread	700	1,360	12
<input type="checkbox"/>	CS-HB-625-200	5/8" x 2"	Full thread	700	1,360	12
<input type="checkbox"/>	CS-HB-625-250	5/8" x 2-1/2"	1/4"	700	1,360	12
<input type="checkbox"/>	CS-HB-625-300	5/8" x 3"	Full thread	700	1,360	12
<input type="checkbox"/>	CS-HB-625-350	5/8" x 3-1/2"	Full thread	700	1,360	12

* Torque values displayed are in ft/lbs unless noted otherwise. Values shown represent a 3:1 safety factor.

CHAMPION STRUT™ FIBERGLASS-REINFORCED HEX NUTS

Champion Strut fiberglass reinforced hex nuts are available in two styles; hex head flange and hex head. The hex head flange nuts incorporate a molded washer collar flange that distributes torque pressure where the hex flange nut meets the mating surface thereby eliminating the need for a separate washer and minimizing the need for additional hardware.

FIBERGLASS-REINFORCED POLYURETHANE HEX HEAD FLANGE NUTS

Fiberglass reinforced hex head flange nuts are available in sizes from 3/8" diameter through 5/8" diameter. Hex head flange nuts are packaged in bags containing 25 pieces.

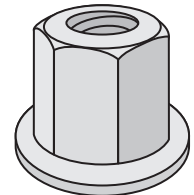

	ITEM NO	NUT SIZE (IN)	THREAD SHEAR (LBS)	HEIGHT (IN)	TORQUE* (FT/LBS)
<input type="checkbox"/>	CS-FN-375	3/8" – 16	500	.75"	3
<input type="checkbox"/>	CS-FN-500	1/2" – 13	1,200	.855"	8
<input type="checkbox"/>	CS-FN-625	5/8" – 11	2,200	1.22"	12

* Torque values shown represent a 3:1 safety factor.

FIBERGLASS-REINFORCED POLYURETHANE HEX HEAD NUTS

Fiberglass-reinforced hex head nuts are available in sizes from 1/4" diameter through 5/8" diameter. Hex head nuts are packaged in bags containing 25 pieces.

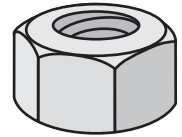

	ITEM NO	NUT SIZE (IN)	THREAD SHEAR (LBS)	HEIGHT (IN)	TORQUE* (FT/LBS)
<input type="checkbox"/>	CS-HN-250	1/4" – 20	150	.218"	10**
<input type="checkbox"/>	CS-HN-312	5/16" – 18	150	.218"	10**
<input type="checkbox"/>	CS-HN-375	3/8" – 16	460	.328"	3
<input type="checkbox"/>	CS-HN-500	1/2" – 13	800	.437"	8
<input type="checkbox"/>	CS-HN-625	5/8" – 11	1,000	.546"	12

* Torque values shown represent a 3:1 safety factor.

** Torque value displayed is in/lbs.

VINYL ESTER FIBERGLASS SQUARE NUTS

Vinyl ester fiberglass square nuts are available in sizes from 3/8" diameter through 5/8" diameter. They are manufactured from pultruded vinyl ester square material and are ideal for applications that require higher thread shear. Square nuts are packaged in bags containing 25 pieces.

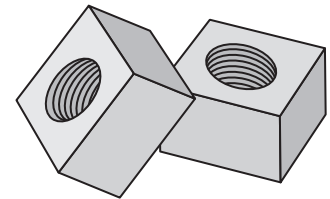

	ITEM NO	NUT SIZE (IN)	THREAD SHEAR (LBS)	HEIGHT (IN)	TORQUE* (FT/LBS)
<input type="checkbox"/>	CS-SN-375	3/8" – 16	1,300	.437"	10
<input type="checkbox"/>	CS-SN-500	1/2" – 13	1,700	.562"	10
<input type="checkbox"/>	CS-SN-625	5/8" – 11	1,700	.687"	10

* Load values shown represent a 3:1 safety factor.

CHAMPION STRUT™ POLYURETHANE FLAT WASHERS

Champion Strut flat washers are made from 1/8" thick glass reinforced polyurethane and are available for 3/8" diameter through 5/8". Washers are recommended for the connections that utilize hex head cap screws and hex head nuts. Polyurethane washers are packaged in bags containing 25 pieces.

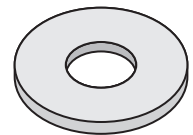

	ITEM NO	SIZE (IN)	OUTSIDE DIAMETER (IN)
<input type="checkbox"/>	CS-PW-312	5/16"	1.00"
<input type="checkbox"/>	CS-PW-375	3/8"	1.00"
<input type="checkbox"/>	CS-PW-500	1/2"	1.00"
<input type="checkbox"/>	CS-PW-625	5/8"	1.25"

CHAMPION STRUT™ PVC FLAT WASHERS

Champion Strut flat washers are made from PVC and are available for 1/4" diameter through 5/8." PVC washers are recommended for the connections that utilize hex head cap screws and hex head nuts. PVC washers are packaged in bags containing 25 pieces.

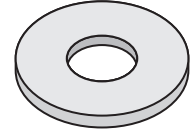

	ITEM NO	SIZE (IN)	OUTSIDE DIAMETER (IN)
<input type="checkbox"/>	CS-FW-250	1/4"	.49"
<input type="checkbox"/>	CS-FW-375	3/8"	1.00"
<input type="checkbox"/>	CS-FW-500	1/2"	1.25"
<input type="checkbox"/>	CS-FW-625	5/8"	1.50"

CHAMPION STRUT™ CHANNEL NUTS

Champion Strut channel nuts are engineered and designed to provide maximum surface area engagement and pull-out strength with the strut flanges of the CS-S Series fiberglass channels. These channel nuts can only be used with the CS-S Series fiberglass channels due to the unique design of the strut flanges. All channel nuts are manufactured from glass-reinforced polyurethane and are packaged in bags containing 25 pieces.

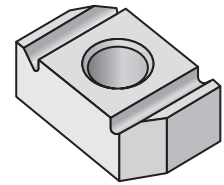

	ITEM NO	CHANNEL NUT SIZE (IN)	THREAD SHEAR (LBS)*	TORQUE* (FT/LBS)
<input type="checkbox"/>	CS-CN-375	3/8" – 16	460	3
<input type="checkbox"/>	CS-CN-500	1/2" – 13	460	3

* Torque values shown represent a 3:1 safety factor.

CHAMPION STRUT™ SADDLE CLIPS

Champion Strut saddle clips are injection molded from glass-reinforced polyurethane and available in 3/8" and 1/2" sizes. The saddle clips (also referred to as square washers) can be used to center and stabilize fiberglass all-thread rods when installing piping or conduit trapeze hanger supports. The saddle clips are packaged in bags containing 25 pieces.

	ITEM NO	HOLE SIZE (IN)
<input type="checkbox"/>	CS-SC-375	3/8"
<input type="checkbox"/>	CS-SC-500	1/2"
<input type="checkbox"/>	CS-SC-625	5/8"

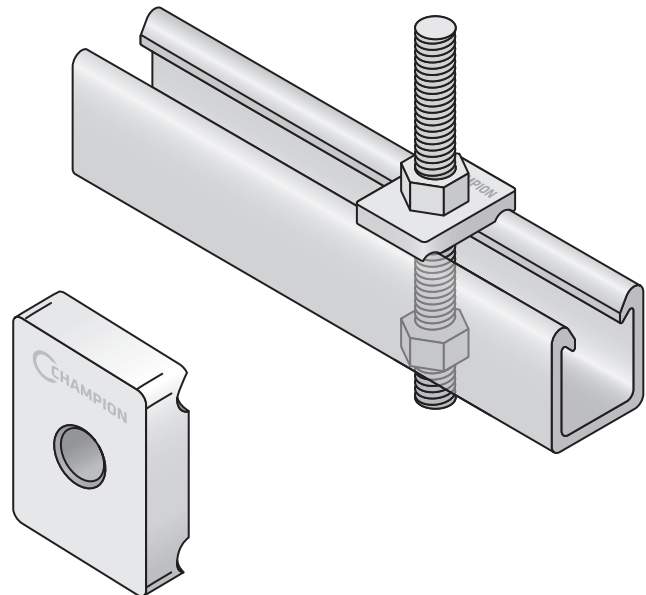

CHAMPION STRUT™ STOP-LOCK ASSEMBLY

Champion Strut stop-lock assemblies are recommended to reduce or eliminate potential slippage of piping or conduit installed in vertical channel applications. Stop-lock assemblies will also assist with applications that may be subjected to vibration or have regular contact with fluids.

The stop-lock assembly consists of three components; a polyurethane hex flange bolt, a saddle clip and a channel nut. The stop-lock assemblies are available in 3/8" and 1/2" sizes and can only be used with the CS-S Series fiberglass channels due to the unique design of the strut flanges.

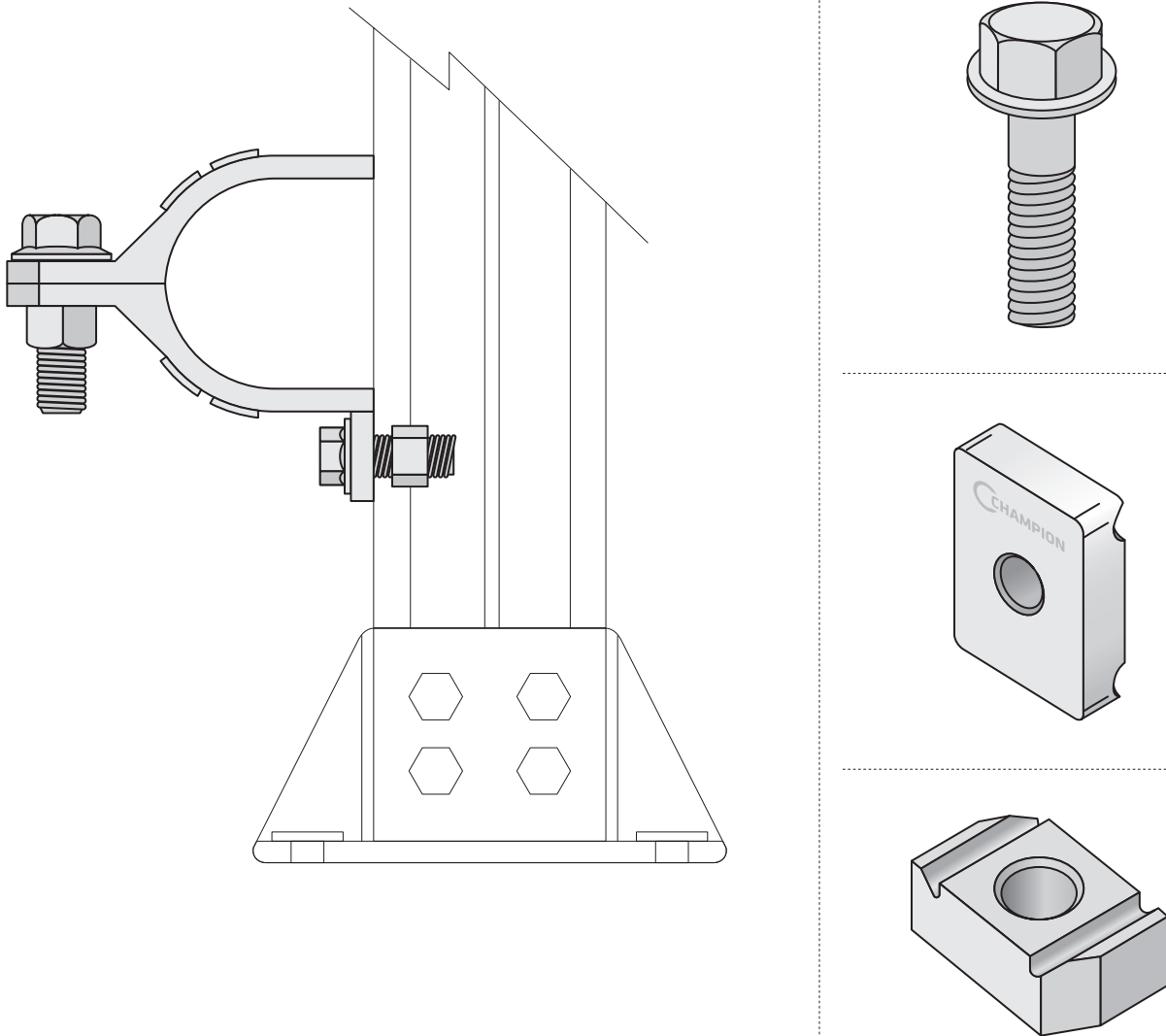

	ITEM NO	CHANNEL NUT SIZE (IN)	FORCE* RESISTANCE (LBS)	TORQUE* (FT/LBS)
<input type="checkbox"/>	CS-SL-375	3/8" – 16	200	3
<input type="checkbox"/>	CS-SL-500	1/2" – 13	220	3

* Force resistance and torque values shown represent a 3:1 safety factor.

Champion Strut™ Pipe and Conduit Hangers

Champion Fiberglass is the leading manufacturer of pipe and conduit hangers. For over 28 years, our hangers have been recognized for their ability to make your installations easier and more cost efficient. You'll find them on pipe racks, bridge and DOT applications all over the world – and as every application is unique, Champion Fiberglass will work with you to provide specialized designs if needed.



For further information, use your smart phone's camera or QR code scanner to view the **Champion Fiberglass Bridge Hanger Video**, which details how to install hangers (spacing) and how to locate the conduit expansion joints, split ring anchors and anchor hangers.



Features

All hangers are constructed from the following grey polyester fiberglass components; special colors can be customized upon request.

- 1/2" x 2" FRP flat bar
- 1" x 1/8" FRP round tube
- 1/4" x 2" FRP square tube

Steel Champion Bridge Hanger Rods can be supplied in the following 3/4" diameter options.

- 3/4"-10 HDG
- 3/4"-10-304 stainless steel
- 3/4"-10-316 stainless steel

Domestic steel must be specified if required.

Customization

- You can create customized piping/conduit hangers on our website – visit championfiberglass.com/product/champion-hangers to begin.
- Scroll down to "Get Estimate" and choose Intermediate or Anchor Hangers.
- Click the configuration you'd like a quote on. Fill out the quote form and hit the "Submit" button, or print/save to mail to Champion Fiberglass. Someone will contact you.

Availability and Installation

Champion Fiberglass will provide all information and technical assistance required.

- Fiberglass hangers are recommended for fiberglass piping and fiberglass electrical conduit to prevent abrasion during expansion/contraction.
- Pipe and Conduit Hangers can be installed and used with all piping and conduit material types.

Pipe and Conduit Hanger Types

The Champion Fiberglass Pipe and Conduit Hanger system consists of two hanger types, Intermediate Hangers and Anchor Hangers.

Intermediate Hangers

The Intermediate Hangers are the most widely used type of pipe and conduit support hanger. The Intermediate Hanger consists of a trapeze hanging system comprised of fiberglass flat bar, (and/or) fiberglass square tube and 3/4" steel threaded rods that are attached to the underside of the building structure. Fiberglass hangers are recommended for fiberglass piping and conduit to prevent abrasion of conduit during expansion/contraction.

Standard and Alternate Intermediate Pipe and Conduit Hanger Configurations

Intermediate Pipe and Conduit Hangers are offered in standard and alternate design configurations (see below). All design configurations utilize the same fiberglass components and steel hanger rods. Alternate design configurations must be specified by customer.

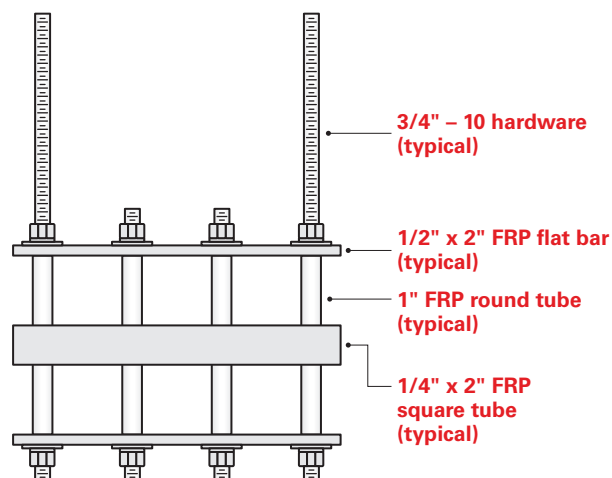

Intermediate Hanger /
Flat Bar-Square Tubing-Flat

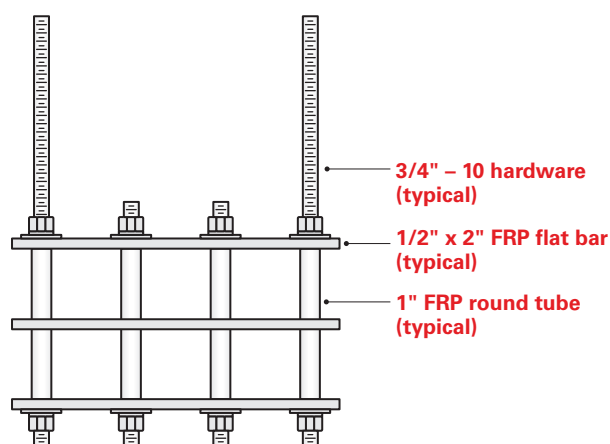

Standard Intermediate Hanger

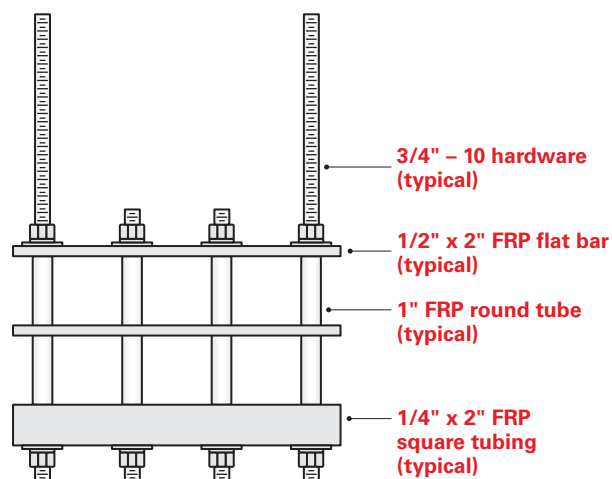

Intermediate Hanger /
Flat Bar-Square Tube Bottom

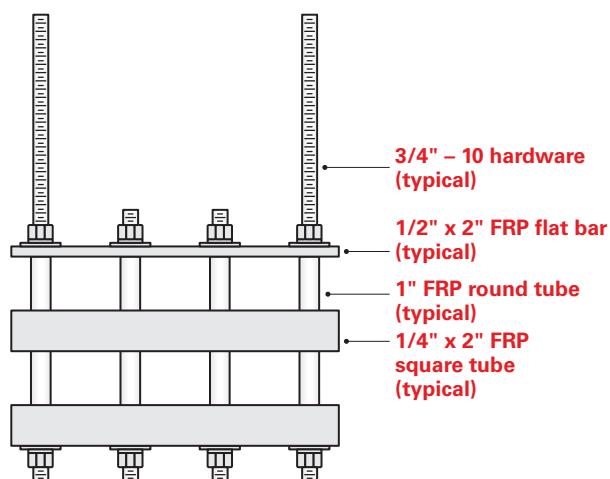

Intermediate Hanger /
Flat Bar-Square Tubing

Standard and Alternate Intermediate Pipe and Conduit Hanger Configurations
continued

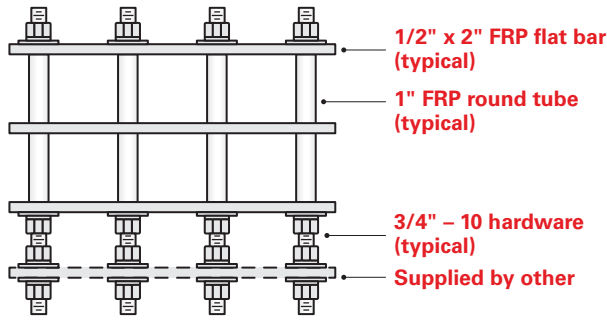

Base Mount Hanger

Note: For piping and conduit hangers 4" and larger, the 1/4" x 2" square tubing is recommended. Piping and conduit hangers constructed with square tubing allow for maximum pipe and conduit support.

Anchor Hangers

The Anchor Hanger are only recommended for fiberglass electrical conduit supports. These hangers are the same construction as the Intermediate Hanger except that each hanger contains adjustable extending all-thread cross-members that are used to brace the hanger to the building structure.

Anchor Hangers are recommended every 200 ft and used to lock the fiberglass electrical conduit into place. Locking the conduit into place allows the conduit system expansion joints to function as designed.

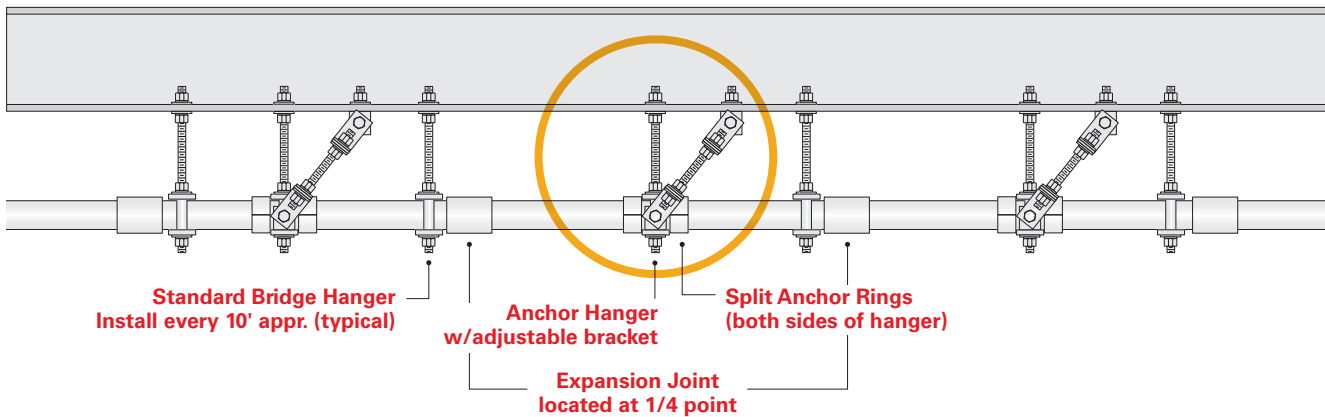

Location of Supports

The actual location of the hanger supports are determined by two factors:

- What the National Electric Code (NEC) stipulates regarding electrical conduit.
- If not guided by the NEC, the conduit/pipe deflection should be used as a guideline for determining the support distances. After determining the total weight contained within the conduit or pipe, the support span distance is determined based on the maximum allowable mid-span deflection. Champion Fiberglass recommends not exceeding 5/8" mid-span deflection.

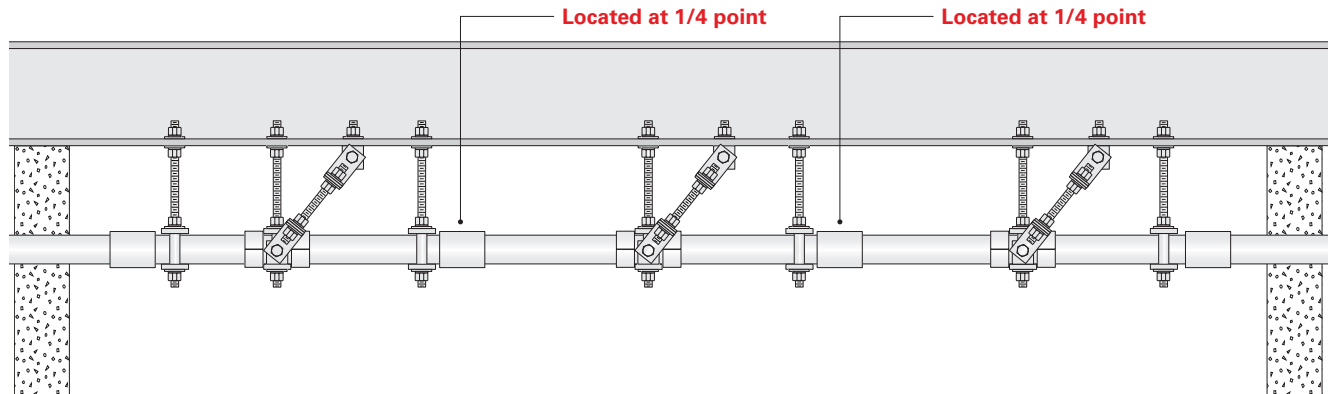

Note: For hangers 4" and larger, the 1/4" x 2" square tubing is recommended. Hangers constructed with square tubing allow for maximum support spans.

Specifications for Fiberglass Hangers

Fiberglass Components Specifications

The fiberglass components shall be manufactured from isophthalic polyester resin and contain ultraviolet inhibitors. They shall be fire retardant and exhibit low smoke generation. The fiberglass components shall be grey in color (special hanger colors can be customized upon request) and shall meet or exceed the following:

Fiberglass Square Tube, Flat Bar and Round Spacer Tube

MECHANICAL PROPERTIES	ASTM	ENGLISH		METRIC	
		VALUE	UNITS	VALUE	UNITS
Tensile Strength	D638	30,000	psi	206.8	MPa
Tensile Modulus	D638	2.5 x 10 ⁶	psi	17.2	GPa
Compressive Strength	D695	30,000	psi	206.8	MPa
Compressive Modulus	D695	2.5 x 10 ⁶	psi	17.2	GPa
Flexural Strength	D790	30,000	psi	206.8	MPa
Flexural Modulus	D790	1.8 x 10 ⁶	psi	12.4	GPa
Modulus of Elasticity	–	2.8 x 10 ⁶	psi	19.3	GPa
Shear Modulus	–	0.45 x 10 ⁶	psi	3.1	GPa
Short Beam Shear	D2344	4,500	psi	31.0	MPa
Punch Shear	D256	10,000	psi	68.9	MPa
Impact Strength	D256	25	ft-lbs/in	1.33	J/mm

PHYSICAL PROPERTIES	ASTM	ENGLISH		METRIC	
		VALUE	UNITS	VALUE	UNITS
Barcol Hardness	D2583	45	–	–	–
24-hour Water Absorption	D570	0.45%	max	–	–
Density	D792	.062 – .070	lbs/in ³	1.72 – 1.94	g/cc
Coefficient of Thermal Expansion	D696	4.4	10 ⁻⁶ in/in/°F	8	10 ⁻⁶ cm/cm/°C

ELECTRICAL PROPERTIES	ASTM	ENGLISH		METRIC	
		VALUE	UNITS	VALUE	UNITS
Arc Resistance	D495	120	seconds	–	–
Dielectric Strength	D149	35	kv/in	1.37	kv/mm

FLAMMABILITY PROPERTIES	ASTM	ENGLISH	
		VALUE	UNITS
Tunnel Test	E84	25	max
Flammability	D635	Nonburning	–
UL	94	VO	–
Smoke Chamber	E662	600 – 700	–

The specifications below detail the requirements for hangers used to support piping and conduit from structures. The hangers shall be shipped fully assembled with all necessary components. All hex nuts shall be tightened to a “snug fit” unless specified otherwise.

Steel Hardware Specifications

The steel support rods, intermediate rods and metallic hardware will be manufactured as hot dipped galvanized steel, 304 stainless steel or 316 stainless steel.

Hot Dipped Galvanized Hardware

The support rods, intermediate rods and all metallic hardware shall be hot dipped galvanized steel and shall meet or exceed the following:

- Threaded rod ASTM A-307 with ASTM 153 galvanizing tensile strength 74,000 psi
- Hex nut ASTM A-307 with ASTM 153 galvanizing
- Flat washer ASTM A-307 with ASTM 153 galvanizing
- Lock washer ASTM A-307 with ASTM 153 galvanizing

Metal components that are custom fabricated shall have a hot dipped galvanizing applied in accordance with ASTM specification a-123/123m2 dated 2002 with a minimum coating thickness of 2.0 oz/sq ft. The zinc used in this process shall be a high-grade zinc conforming to ASTM B6-00 with less than .03% lead used in this process.

304 Stainless Steel Hardware

The support rods, intermediate rods and all metallic hardware shall be stainless steel and shall meet or exceed the following:

- Threaded rod SS304 ASTM A-193 grade B8
- Hex nut ASTM SS304 A-194 grade 8
- Flat washer SS18-8
- Lock washer SS18-8

Metal components that are custom fabricated shall be stainless steel 304 in accordance with ASTM specification A193/A193M-94b dated 1994.

316 Stainless Steel Hardware

The support rods, intermediate rods and all metallic hardware shall be stainless steel and shall meet or exceed the following:

- Threaded rod SS316 ASTM A-193 grade B8M
- Hex nut ASTM SS316 A-194 grade 8M
- Flat washer SS18-8
- Lock washer SS18-8

Metal components that are custom fabricated shall be stainless steel 316 in accordance with ASTM specification A193/A193M-94b dated 1994.

Domestic steel can be provided upon request.

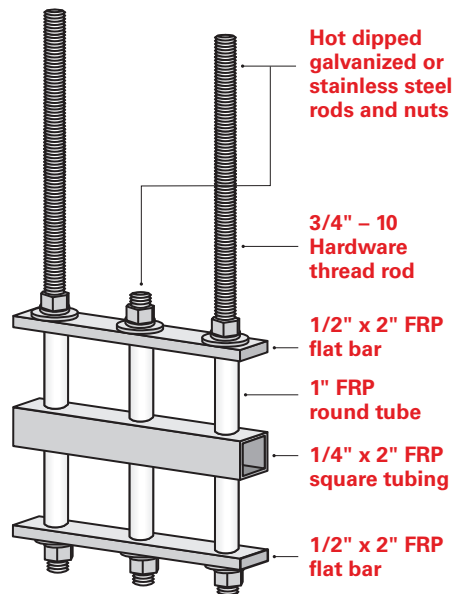

Pipe and Conduit Hangers

CHAMPION STRUT™ CLEVIS HANGERS

Champion Strut clevis hangers are available in two types; injection molded glass-reinforced polyurethane and polyester or vinyl ester hand lay-up. The injection molded glass-reinforced clevis hangers are available for sizes 1/2" through 6". The hand lay-up clevis hangers are standardly provided in polyester fiberglass and available in sizes 1" through 24". Vinyl ester clevis hangers are available as a special-order item. Contact Champion Fiberglass for pricing and availability on vinyl ester clevis hangers.

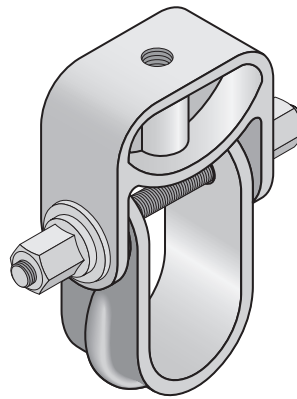

Molded

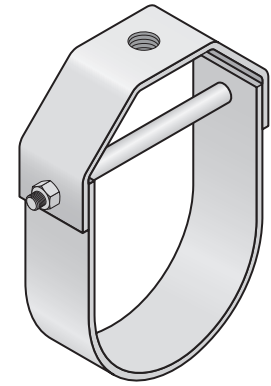

Hand Lay-up

CHAMPION STRUT™ MOLDED CLEVIS HANGERS

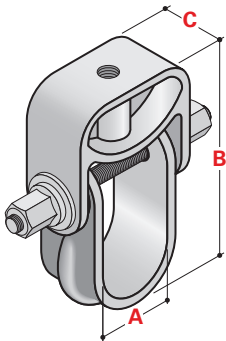

	ITEM NO	NOMINAL SIZE (IN)	MAX PIPE OD (IN)	DIMENSIONS			HANGER ROD SIZE (IN)	LOAD* (LBS)
				A (IN)	B (IN)	C (IN)		
<input type="checkbox"/>	CS-MCH-100	1/2" – 1"	1"	1.50"	4.25"	1.25"	1/2"	670
<input type="checkbox"/>	CS-MCH-150	1-1/4" – 1-1/2"	1-1/2"	2.00"	5.14"	1.25"	1/2"	670
<input type="checkbox"/>	CS-MCH-200	1-1/2" – 2"	2"	2.50"	6.52"	1.25"	1/2"	730
<input type="checkbox"/>	CS-MCH-400	2-1/2" – 4"	4"	5.13"	10.00"	1.50"	1/2"	1,150
<input type="checkbox"/>	CS-MCH-600	4-1/2" – 6"	6"	6.75"	12.33"	1.50"	1/2"	1,170

* Load values shown represent a 3:1 safety factor.



CHAMPION STRUT™ HAND LAY-UP CLEVIS HANGERS

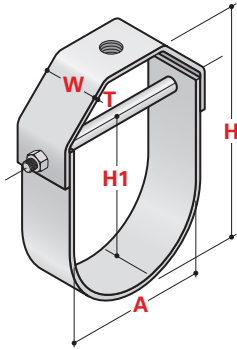

	ITEM NO	NOMINAL SIZE (IN)	T (IN)	H (IN)	H1 (IN)	W (IN)	HANGER ROD SIZE (IN)	TRANS ROD SIZE (IN)	SPREADER ROD SIZE (IN)	LOAD* (LBS)
<input type="checkbox"/>	CS-LCH-10	1" – 1-1/2"	1/8"	2.75"	1.875"	1.50"	1/2"	3/8"	1/2"	60
<input type="checkbox"/>	CS-LCH-15	1-1/2" – 2"	1/8"	3.50"	2.375"	1.50"	1/2"	3/8"	1/2"	60
<input type="checkbox"/>	CS-LCH-20	2" – 2-5/8"	1/8"	4.75"	3.00"	2.00"	1/2"	3/8"	1/2"	90
<input type="checkbox"/>	CS-LCH-25	2-1/2" – 3-1/4"	1/8"	5.50"	3.625"	2.00"	1/2"	3/8"	1/2"	120
<input type="checkbox"/>	CS-LCH-30	3" – 3-7/8"	1/8"	7.00"	4.250"	2.00"	5/8"	3/8"	1/2"	160
<input type="checkbox"/>	CS-LCH-40	4" – 5-1/8"	3/16"	8.50"	5.625"	2.00"	5/8"	3/8"	1/2"	250
<input type="checkbox"/>	CS-LCH-60	6" – 7-1/8"	3/16"	10.875"	7.50"	3.00"	5/8"	3/8"	1/2"	300
<input type="checkbox"/>	CS-LCH-80	8" – 9-1/4"	1/4"	14.00"	9.75"	3.00"	5/8"	3/8"	1/2"	350
<input type="checkbox"/>	CS-LCH-100	10" – 11-3/8"	1/4"	18.00"	12.00"	4.00"	5/8"	1/2"	3/4"	450
<input type="checkbox"/>	CS-LCH-120	12" – 13-1/2"	1/4"	21.50"	14.125"	5.00"	5/8"	1/2"	3/4"	600
<input type="checkbox"/>	CS-LCH-140	14" – 15-3/4"	1/4"	24.50"	16.50"	5.00"	3/4"	1/2"	3/4"	700
<input type="checkbox"/>	CS-LCH-160	16" – 18"	3/8"	27.375"	19.50"	6.00"	3/4"	3/4"	1"	750
<input type="checkbox"/>	CS-LCH-190	19" – 21"	3/8"	34.50"	22.50"	6.00"	3/4"	3/4"	1"	800
<input type="checkbox"/>	CS-LCH-210	21" – 22"	1/2"	35.50"	24.00"	6.00"	3/4"	3/4"	1"	850
<input type="checkbox"/>	CS-LCH-220	22" – 24"	1/2"	41.00"	28.00"	6.00"	3/4"	3/4"	1"	900

* Load values shown represent a 3:1 safety factor.

Pipe Hanging Accessories

CHAMPION STRUT™ BEAM MOLDED CLAMPS

The Champion Strut system has two types of molded beam clamps; light-duty and heavy-duty. The light-duty beam clamp has a 3/4" jaw opening and is available for both 3/8" and 1/2" threaded rod sizes and is not available with a "I" beam securing beam clip. The heavy-duty beam clamp has a 1" jaw opening and is available for 3/8", 1/2" and 5/8" threaded rod sizes. The heavy-duty beam clamp can be combined with the "I" beam securing beam clip for additional stability. Both the light-duty and heavy-duty beam clamps are provided with a 316 stainless steel hex head set screw.

CHAMPION LIGHT-DUTY MOLDED BEAM CLAMP

	ITEM NO	THREADED ROD SIZE (IN)	THREAD SHEAR (LBS)	TORQUE (FT/LBS)
<input type="checkbox"/>	CS-BC-375	3/8"	400	10
<input type="checkbox"/>	CS-BC-500	1/2"	400	10

* Load values shown represent a 3:1 safety factor

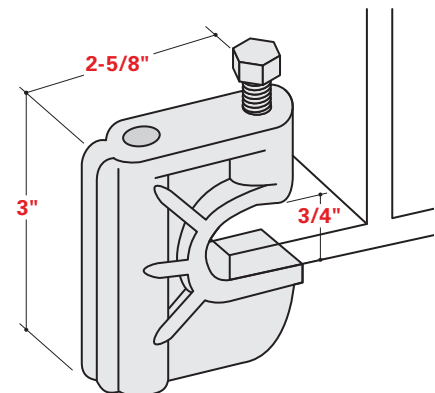

CHAMPION HEAVY-DUTY MOLDED BEAM CLAMP

	ITEM NO	THREADED ROD SIZE (IN)	THREAD SHEAR (LBS)	TORQUE (FT/LBS)
<input type="checkbox"/>	CS-BCH-375	3/8"	500	10
<input type="checkbox"/>	CS-BCH-500	1/2"	500	10
<input type="checkbox"/>	CS-BCH-625	5/8"	500	10

* Load values shown represent a 3:1 safety factor.

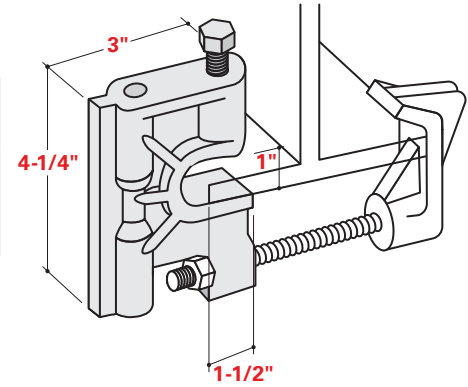
**CHAMPION STRUT™ MOLDED BEAM CLAMP CLIP**

The molded beam clamp clip is available as an accessory item for the heavy-duty beam clamp. The beam clamp clip is designed to prevent any beam clamp movement that may be caused by vibration.

	ITEM NO	THREADED ROD SIZE (IN)
<input type="checkbox"/>	CS-BCC-375	3/8"

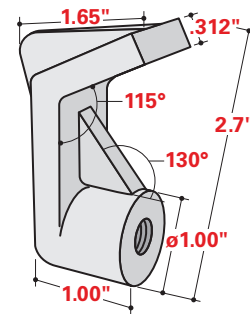
**CHAMPION STRUT™ FABRICATED BEAM CLAMPS**

The fabricated beam clamp consists of a combination of parts (1/2" hex head flange bolt and 1/2" CS-CN500 channel nut) available in the Champion Strut system. The clips can be supplied in either polyester or vinyl ester fiberglass materials.

	ITEM NO	FLANGE THICKNESS	MATERIAL TYPE	THREAD SHEAR (LBS)	TORQUE (FT/LBS)
<input type="checkbox"/>	CS-FBC-250P	1/4"	Polyester	500	10
<input type="checkbox"/>	CS-FBC-250V	1/4"	Vinyl Ester	500	10
<input type="checkbox"/>	CS-FBC-375P	3/8"	Polyester	500	10
<input type="checkbox"/>	CS-FBC-375V	3/8"	Vinyl Ester	500	10
<input type="checkbox"/>	CS-FBC-500P	1/2"	Polyester	500	10
<input type="checkbox"/>	CS-FBC-500V	1/2"	Vinyl Ester	500	10

* Load values shown represent a 3:1 safety factor.

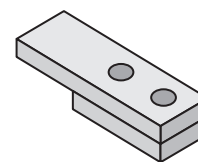
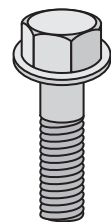
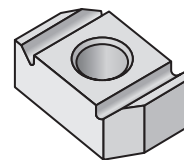
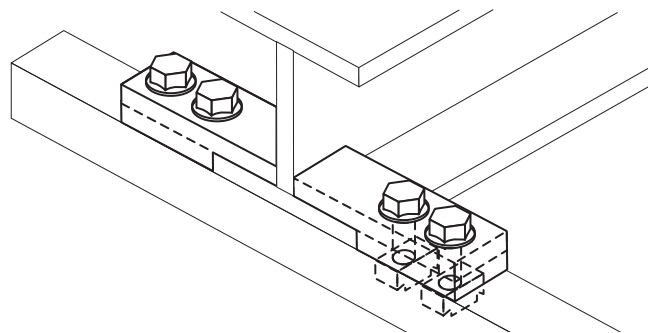

CHAMPION STRUT™ FIBERGLASS THREADED ROD

Fiberglass threaded rods are typically used to construct trapeze hangers from Champion Strut fiberglass channels. Champion Strut threaded rods are manufactured from pultruded vinyl ester resin rod and are grey in color. The threaded rod is supplied in both 4- and 8-ft lengths.

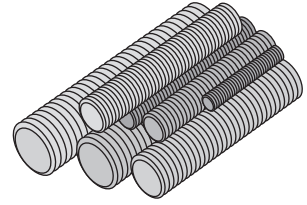

	ITEM NO	SIZE (IN)	LENGTH (FT)	THREAD SHEAR (LBS)	TORQUE (FT/LBS)
<input type="checkbox"/>	CS-TR-375-4	3/8"	4 ft	800	5
<input type="checkbox"/>	CS-TR-375-8	3/8"	8 ft	800	5
<input type="checkbox"/>	CS-TR-500-4	1/2"	4 ft	870	10
<input type="checkbox"/>	CS-TR-500-8	1/2"	8 ft	870	10
<input type="checkbox"/>	CS-TR-625-4	5/8"	4 ft	1,500	40
<input type="checkbox"/>	CS-TR-625-8	5/8"	8 ft	1,500	40

* Load values shown represent a 3:1 safety factor.

PROPERTIES	3/8" – 16 UNC	1/2" – 13 UNC	5/8" – 11 UNC
Thread shear strength using fiberglass nut in tensile (lbs)	1,250	2,500	3,800
Transverse shear on threaded rod – double shear ASTM B-565 (load lb)	4,200	7,400	11,600
Transverse shear on threaded rod – single shear (load lb)	1,600	2,600	3,800
Compressive strength – longitudinal ASTM D-695 (psi)	55,000	55,000	55,000
Flexural strength ASTM D-790 (psi)	60,000	60,000	60,000
Flexural modulus ASTM D-790 (psi x 10 ⁶)	2.0 x 10 ⁶	2.0 x 10 ⁶	2.0 x 10 ⁶
Torque strength using fiberglass nut lubricated with SAE 10W30 motor oil (ft/lbs)	8	15	33
Dielectric strength ASTM D-149 (kv/in)	40	40	40
Water absorption 24-hour immersion – threaded ASTM D-570 (%)	1	1	1
Coefficient of thermal expansion – longitudinal (in/in/°F)	5 x 10 ⁶	5 x 10 ⁶	5 x 10 ⁶
Max recommended operation temp, based on 50% retention of ultimate thread shear length (°F)	200	200	200
Stud weight (lb/ft)	.076	.129	.209
Flammability	Self extinguishing per UL94V-0		

Threaded rod is a proprietary combination of fiberglass and Class I vinyl ester flame-retardant resin.

CHAMPION STRUT™ FIBERGLASS THREADED ROD COUPLERS

The Champion Strut fiberglass threaded rod couplers are designed to connect lengths of Champion Strut fiberglass threaded rod. The rod couplers are manufactured from injection molded polyurethane resin and are available for 3/8" and 1/2" threaded rod sizes.

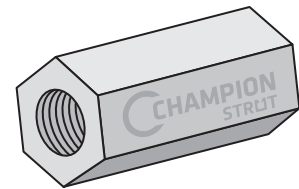

	ITEM NO	SIZE (IN)	LENGTH (LBS)	THREAD SHEAR (FT/LBS)
<input type="checkbox"/>	CS-TRC-375	3/8"	2-1/4"	800
<input type="checkbox"/>	CS-TRC-500	1/2"	2-1/4"	870

Wall Support Racks

CHAMPION STRUT™ WALL BRACKETS

Champion Strut wall brackets are typically used to support piping, electrical conduits or cable trays that will be wall mounted. Each wall bracket has a maximum load rating of 750 lbs with a 3.0 safety factor on a uniformly distributed load. Bracket spacing may be determined by dividing 750 lbs by the piping, electrical conduit or cable tray load by the total load in lbs/ft of piping, conduit or cable tray including its intended material load (fluid or cable).

	ITEM NO	TRAY WIDTH (IN)	DIMENSIONS	
			A (IN)	B (IN)
<input type="checkbox"/>	CS-SR-06-P/V*	6"	10"	10"
<input type="checkbox"/>	CS-SR-09-P/V*	9"	13"	12"
<input type="checkbox"/>	CS-SR-12-P/V*	12"	16"	13"
<input type="checkbox"/>	CS-SR-18-P/V*	18"	22"	16"
<input type="checkbox"/>	CS-SR-24-P/V*	24"	28"	19"
<input type="checkbox"/>	CS-SR-30-P/V*	30"	34"	22"
<input type="checkbox"/>	CS-SR-36-P/V*	36"	40"	25"

* Use P for polyester resin and V for vinyl ester resin.

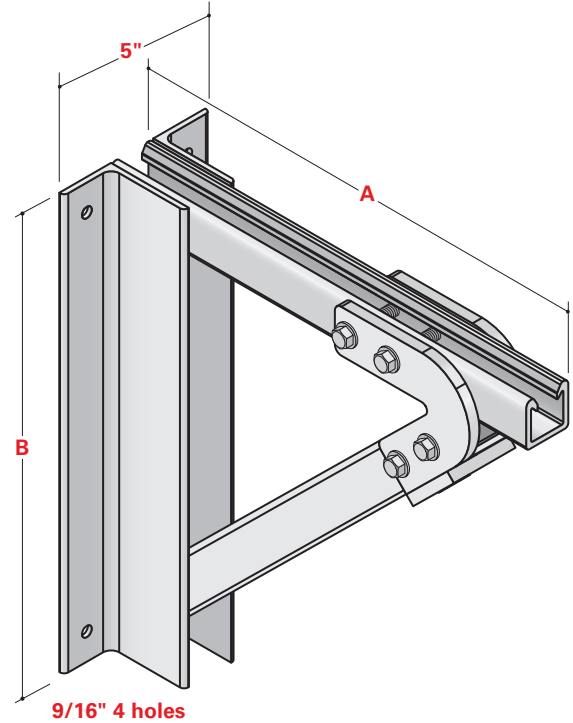

Instruments and Pipe Stands

CHAMPION STRUT™ HEAVY-DUTY POST BASE

The Champion Strut heavy-duty post base is compression molded from corrosion-resistant vinyl ester resin and is available with either a 2" x 2" square tube opening or a 2" IPS round opening that will fit 2" SCH80 pipe. The standard color is black with special colors available upon request.

	ITEM NO	OPENING SIZE (IN)
<input type="checkbox"/>	CS-HDPB-S	2" x 2"
<input type="checkbox"/>	CS-HDPB-R	2" IPS

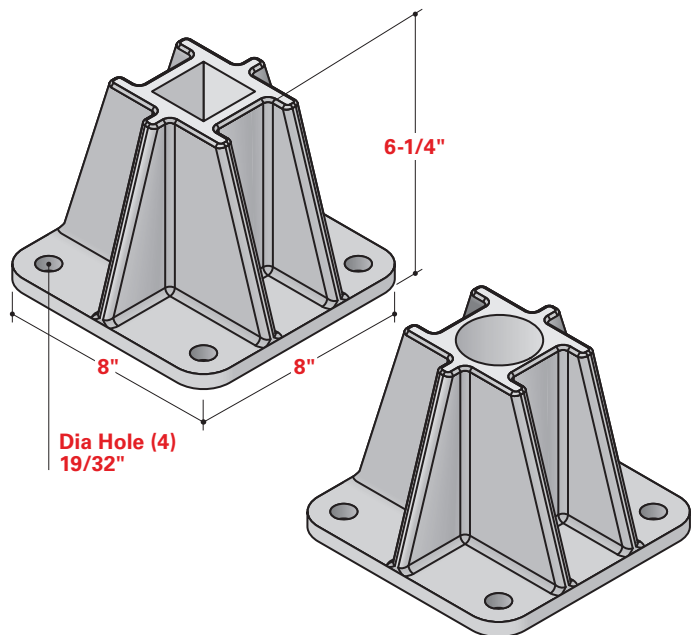

INSTRUMENTS AND PIPE STANDS

Instruments and pipe stands are available in polyester or vinyl ester resin types and are designed to meet specific customer requirements. These stands are ideal for supporting instruments and enclosures in corrosive environments.

Prefabrication of assemblies is available with customer drawings. Prefabrication saves contractors labor and material costs on the job site.



CHAMPION STRUT™ UNIVERSAL INSTRUMENT PIPE SUPPORT AND PUSHBUTTON STATION STANDS

The universal instrument pipe supports and pushbutton station stands are manufactured from 2" filament-wound epoxy resin conduit or 2" x 2" polyester/vinyl ester square tube for increased stiffness and corrosion resistance. The outside diameter of the 2" IPS conduit is 2-3/8" which is identical to 2" steel pipe (or PVC). These systems are non-conductive and resistant to sunlight. The 8" square heavy-duty post base is made from vinyl ester resin, and specially designed with side bracing for extra bending resistance support needed in wall mounted vertical applications. The instrument pipe supports and pushbutton station stands are delivered fully assembled, or available in individual components if so desired. The Champion Strut 2" non-metallic U-bolts (standard and long reach) are excellent devices for attaching instruments, gauges etc. If using 2" x 2" square tubing, polyester or vinyl ester resin must be specified by adding the suffix "-P" for polyester resin or "-V" for vinyl ester resin to the below part numbers. Pricing available upon request.

SINGLE FLOOR MOUNT UNIVERSAL INSTRUMENT PIPE SUPPORT

Part Number: CS-IS1-A (A dimension is defined per sketch) -R or -S*

* "-R" for round 2" pipe or "-S" for 2" x 2" square tubing. If "-S" please specify by adding the suffix "-P" for polyester resin or "-V" for vinyl ester resin to the part number.

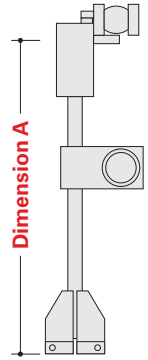

WALL OR FLOOR MOUNT UNIVERSAL INSTRUMENT PIPE SUPPORT

Part Number: CS-IS2-A (dimension) -B (dimension) -R or -S*

* "-R" for round 2" pipe or "-S" for 2" x 2" square tubing. If "-S" please specify by adding the suffix "-P" for polyester resin or "-V" for vinyl ester resin to the part number.

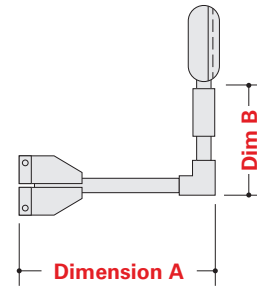

DOUBLE FLOOR MOUNT UNIVERSAL INSTRUMENT PIPE SUPPORT

Part Number: CS-IS3-A (dim) -B (dim) -C (dim) -R or -S*

* "-R" for round 2" pipe or "-S" for 2" x 2" square tubing. If "-S" please specify by adding the suffix "-P" for polyester resin or "-V" for vinyl ester resin to the part number.

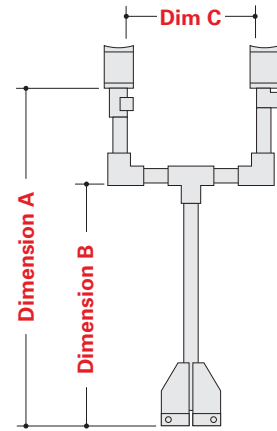

MULTIPLE INSTRUMENT FLOOR MOUNT UNIVERSAL INSTRUMENT PIPE SUPPORT

Part Number: CS-IS4-A (dim) -B (dim) -C (dim) -R or -S*

* "-R" for round 2" pipe or "-S" for 2" x 2" square tubing. If "-S" please specify by adding the suffix "-P" for polyester resin or "-V" for vinyl ester resin to the part number.

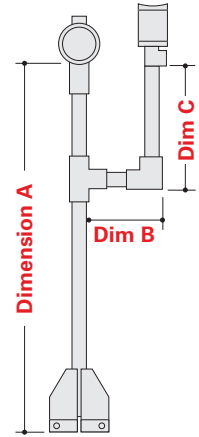

PUSHBUTTON STATION STANDS

Pushbutton Station Stands are similar to the Universal Instrument Pipe Support stands except they only utilize 2" x 2" polyester or vinyl ester square tubing and fiberglass back panel.

Part Number: CS-IS4-A (dim) -B (dim) -C (dim) -S*

* Please specify resin type by adding the suffix "-P" for polyester resin or "-V" for vinyl ester resin to the part number.

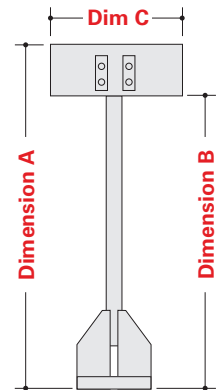

CHAMPION STRUT™ FIELD CUTTING SEALANT

Champion Seal Field Cutting Sealant seals exposed fibers after field cuts and restores gloss and luster to weathered fiberglass.

This is an excellent sealer for cut and drilled holes in fiberglass pultruded products as well as fiberglass threaded rods. This sealer exceeds vinyl ester material in corrosion resistance. It's highly recommended to seal all exposed cut ends, drilled holes and FRP threads after installation. Champion Seal is available in 12 oz spray can.



	ITEM NO	SIZE (OZ)
<input type="checkbox"/>	CS-SEAL-C	12

Promotional Samples

CHAMPION STRUT™ PIPE STAND TABLE DISPLAY

The Champion Strut pipe stand table display is an excellent Champion Strut stocking distributor counter display. It also works well as a trade show display for Champion Strut sales representatives. This display features a multitude of channels and accessories and illustrates the versatility of the Champion Strut system.



	ITEM NO
<input type="checkbox"/>	CS-DIST-DISP

CHAMPION STRUT™ LITERATURE DISPLAY STAND

The Champion Strut literature display stand is an excellent Champion Strut stocking distributor counter display for Champion Strut literature. It also works well as a literature display at trade shows for Champion Strut sales representatives.



	ITEM NO
<input type="checkbox"/>	CS-LIT-DISP

CHAMPION STRUT™ SAMPLE KIT

The Champion Strut sample kit is a tackle-box of samples provided in a convenient plastic carrying case.

The Champion Strut Sample Kit includes the following items:

- CS-S-20S-P
- CS-S-20D-P
- CS-SST-11-V
- CS-S-10-V
- CS-2500P
- CS-2500V
- CS-SC-500
- CS-PC-100
- CS-CN-500
- CS-MCH-10
- 1/2" threaded rod
- 3/8" threaded rod
- 1/2" rod connector
- CS-FW-500
- CS-PW-500
- CS-FN-500
- CS-HN-500
- CS-FN-375
- CS-HN-375
- CS-FB-375-125
- CS-FB-500-125



	ITEM NO
<input type="checkbox"/>	CS-SAMP-KIT

CHAMPION STRUT™ RIGID PIPE CLAMP DISPLAY SAMPLE

The Champion Strut rigid pipe clamp display sample is a counter or desk sample that illustrates the Champion Strut rigid pipe clamp clamped to PVC pipe on a piece of Champion Strut CS-S Series Channel.

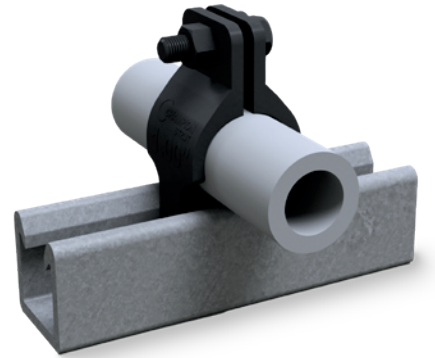

	ITEM NO
<input type="checkbox"/>	CS-RPC-DISP



6400 Spring Stuebner Rd
Spring, TX 77389
Main: 281.655.8900
Fax: 281.257.2523
championfiberglass.com

Champion Fiberglass is also a manufacturer of the following products:



Champion Duct®

Strong, durable Champion Duct conduit, fittings, duct bank and bridge hangers deliver a range of benefits including ease of installation, fire and corrosion resistance, impact resistance, and more. Champion Duct is used in a variety of applications including transportation, data centers, wastewater treatment and chemical plants.



Champion Bridge Drain™

Champion Bridge Drain is a fiberglass bridge drain system that includes a complete line of fittings, non-metallic accessories, and hangers. Champion Bridge Drain is a versatile, high-strength fiberglass bridge drainage system that can be used in highly corrosive drainage applications including bridges, theme parks, aquariums, pools and underground vaults.

